

# 2017-CURRENT F250-550 DEFENDER SERIES GRILLE GAURD

## INSTALLATION INSTRUCTIONS



FOLLOW US ON SOCIAL MEDIA!



@HAMMERHEADARMOR

## SAFETY

**Know Safety, no injury. Know injury, no safety. ~Author Unknown**  
If there are any questions, call 1-855-HHTOUGH

- **READ ALL SAFETY INSTRUCTIONS BEFORE INSTALLATION**
  - FOLLOW ALL INSTRUCTIONS FOR PROPER ASSEMBLY
  - WEAR APPROPRIATE EYE PROTECTION
  - EXERCISE CARE WHEN LIFTING COMPONENTS
  - USE APPROPRIATE TORQUE FOR BOLTS
  - BLUE THREAD LOCKING COMPOUND IS RECOMMENDED ON ALL BOLTS

WARNING: Cancer  
and Reproductive Harm  
  
[www.P65Warnings.ca.gov](http://www.P65Warnings.ca.gov)

Suggested Torque Values For Steel Grade 5 Standard Bolts		
BOLT DIAMETER (INCH)	THREADS PER INCH	TORQUE (POUND - FEET)
1/4	20	7
5/16	18	14
3/8	16	25
7/16	14	40
1/2	13	60
9/16	12	88
5/8	11	120
3/4	10	200
7/8	9	302
1	8	466

Suggested Torque Values For Steel Grade 8.8 Metric Bolts		
BOLT DIAMETER (mm)	THREAD PITCH (mm)	TORQUE (POUND- FEET)
6	1.0	7
8	1.25	16
10	1.5	32
12	1.75	55
14	2.0	88
16	2.0	140
18	2.5	195
20	2.5	275
22	2.5	375
24	3.0	475

**I. PARTS LIST**

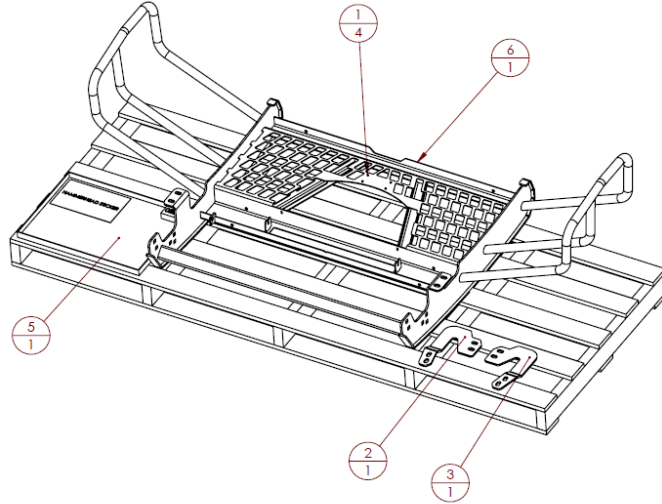

ITEM NO.	QTY	PART NUMBER	DESCRIPTION	
1	4	318-12-0005	0.188" X 0.125" AL POP RIVET	-
2	1	601-56-5602	R LOWER MOUNT	-
3	1	601-56-5603	L LOWER MOUNT	-
4	1	601-56-9992	BLACK HAMMERHEAD LABEL W/ HOLES	-
5	1	60H-56-0013	INSTALL KIT #13	-
6	1	60P-56-1024	600-56-1024 POLISHED	-

**REMOVE CONTENTS FROM BOX AND VERIFY ALL PARTS ARE PRESENT.**

**If there are any questions, call 1-855 HHTOUGH or email [HHORDERS@hammerheadarmor.com](mailto:HHORDERS@hammerheadarmor.com)**

**II. TOOL LIST**

1. A Good Friend
2. Basic Tool Kit
3. Blue Masking Tape
4. 18mm Socket
5. ¾ Socket or Wrench
6. Cutting tool of your choice

### III. VEHICLE PREPARATION

1. Park vehicle on level surface.
2. Engage parking brake and disconnect battery.
3. Using blue masking tape, mask along the profile of your truck above the bumper. This will help protect your truck from any accidental scratches.
4. Remove the 4 outer bolts holding the bumper to the truck using an 18mm socket. There is a weld nut tab on the back of these bolts. Set bolts and tabs aside to be reused.



5. Hook a tape measure on the outer edge of the bumper spoiler and measure around towards the center of the truck. Make a mark at 19.5" and 21". Repeat for both sides.



6. Make a mark at  $\frac{3}{4}$ " and 3" down at each of the 19.5" and 21" marks.



- Using the cutting tool of your choice, carefully cut along your marks to make a rectangular cutout to pass the lower mounts through.



- Using an 18mm socket, remove the two bolts shown below. They are on a stud plate. Make sure not to let the stud plate fall into the frame rail. Set hardware aside to be reused.



#### IV. INSTALLATION OF DEFENDER GRILLE GUARD

- If installing a single row light bar, install it before mounting grille guard to truck.
- With the help of a few friends, or a lifting device, place the grille guard on the truck. Using the hardware removed from the bumper, attach grille guard to truck. Do not fully tighten.

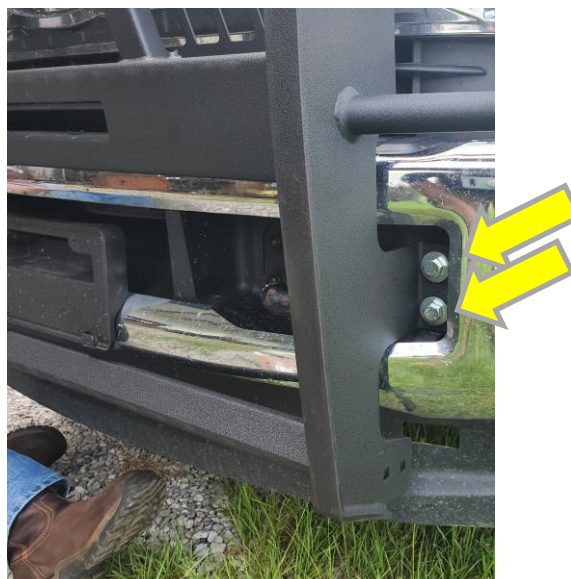



3. Slide lower mounts into place through the cuts in the spoiler and place the mounts over the stud place and reinstall hardware. Use (4) carriage head bolts, washers, and nylock nuts from hardware kit #208 to fasten lower mounts to the grille guard. The mounts should sit to the inside of the grille guard.



4. Align grille guard to the truck and tighten all hardware to the suggested torques listen above.



**Congratulations! Your Installation is now complete.**

**Thank You for your purchase!**