

## Suzuki Samurai 1.3L Carb to 1.6L 8V Fuel Injected Air Intake Adapter (SKU# SEU-AIA)

### Installation Instructions



**CAUTION:** Safety glasses should be worn at all times when working with vehicles and related tools and equipment.



**FOR ADDITIONAL COPIES OF THESE  
AND OTHER INSTRUCTIONS GO TO:**

[www.lowrangeoffroad.com](http://www.lowrangeoffroad.com) and click on the  
"TECH AND INSTRUCTIONS" tab.

#### Suggested Tools:

- Phillips Screwdriver
- Slip-Joint Pliers
- 10 mm Combination Wrench (or 10 mm Socket and Ratchet)
- Pocket Knife
- Permatex Thread-Locker RED

## 1.6L Air Inlet Components

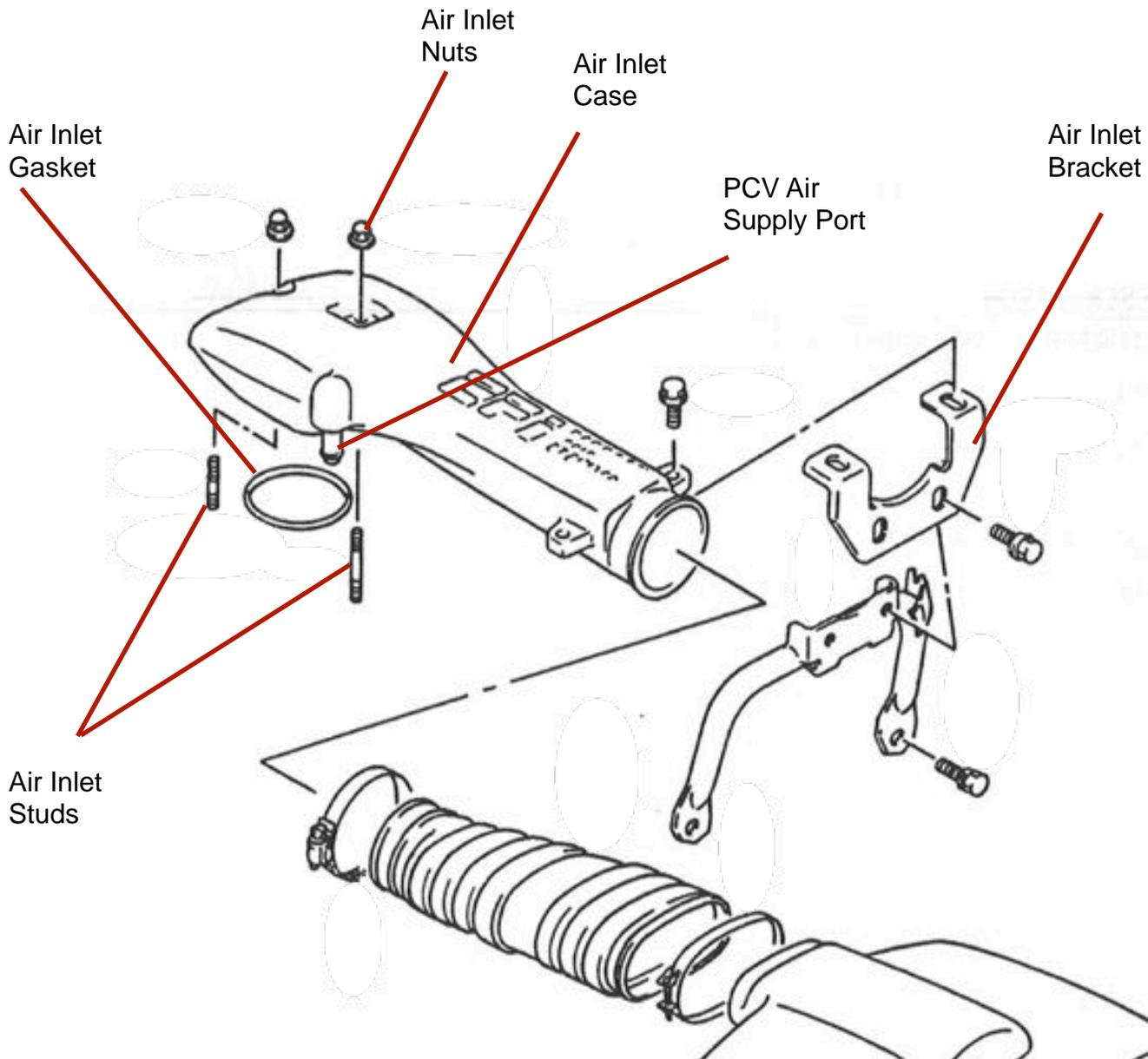

## Removing the 1.6L Air Inlet Case Removal



### Step 1

Disconnect the PCV Hose by expanding the hose clamp using slip joint pliers and sliding the clamp down on the hose. Disconnect the vacuum hose from the air supply port.



### Step 2

Remove the (2) air inlet case attaching nuts using a 10 mm open end wrench.

Note: If there is an air inlet case bracket (see previous page) disconnect it as well.



### Step 3

Remove the air inlet case and set it aside.

Note: Be sure the air inlet case gasket remains in place.



### Step 4

Remove the injector retainer cover by removing the (2) phillips screws using a phillips screwdriver.



### Step 4 Continued

Set the injector retainer cover aside. It will not be reused in this application.



### Step 5

Remove the (2) air inlet studs using slip joint (or vice grip) pliers.

Note: They unscrew in a counter clockwise direction.



### Step 6

Unclip the EGR (Exhaust Gas Recirculation) modulator.



### Step 7

Remove the (2) bolts attaching the EGR Modulator bracket to the throttle body using a 10 mm box end wrench.



### Step 8

Remove the EGR modulator bracket and set it aside. It will not be reused in this application.



### Step 9

Secure the EGR modulator with the existing bendable restraint as shown.



### Step 10

Position the supplied adapter as shown. Be sure the holes align properly.



### Step 11

Install the supplied screws and snug them using a phillips screwdriver.

Note1 Do not over tighten these screw. They are threaded into cast aluminum and are easily stripped.

Note 2: To reduce the risk of these screws working loose and falling down inside the engine, we recommend using [Permatex Threadlocker Red](#) on the threads.



This Side Forward



## 1.3L Samurai Air Inlet & PCV System

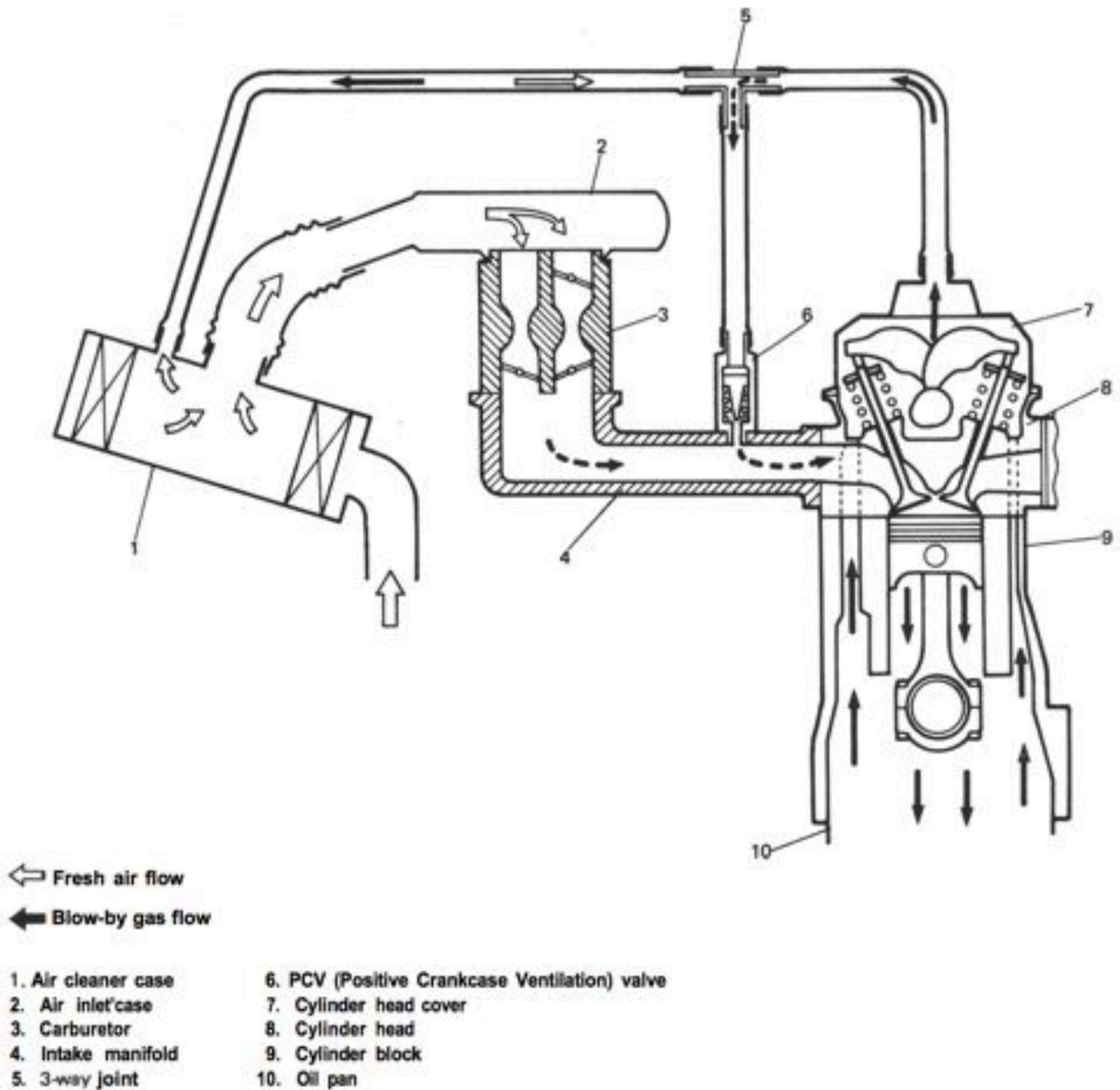

Figure A



## Installing the 1.3 Air Intake System



### Step 12

Position the Samurai air cleaner case as shown.

Note: If the Air Filter is dirty we recommend replacing it. Click [HERE](#) for information about our K&N replacement air filters.

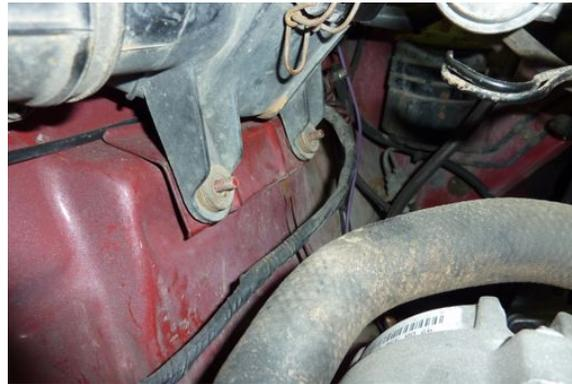

### Step 13

Align the (2) holes on the bottom of the case with the stud.



### Step 14

Align the hole on the top of the case with the hole on the inner fender.



### Step 15

Install the (2) bottom nuts and leave them loose.





## Step 16

Install the top bolt. Tighten all three fasteners using a 10mm box end wrench.



## Step 17

Invert the 1.3L air inlet and cap the port as shown.

Note: We used an 1/8 inch vacuum cap. (Not Included)



## Step 18

Install the 1.3L air inlet case as shown.

Note: Be sure the gasket is still in place.

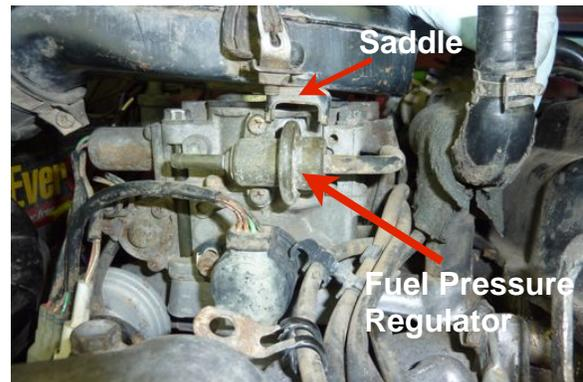

## Step 19

Orient the air inlet case such that the locator saddle fits over the fuel pressure regulator as shown.





### Step 20

Connect the air inlet duct on the air cleaner case.



### Step 21

Install the supplied washer.



### Step 22

Install the supplied thumb nut and tighten.



### Step 23

Tighten the lower inlet hose clamp using a Phillips screwdriver.





### Step 24

Tighten the upper inlet hose clamp if it is not tight.



### Step 25

Connect the air duct as shown.

Note: There is not need to connect anything to the hot air inlet. It is spring loaded in the closed position.



### Step 26

Install the supplied PVC elbow in the PCV air inlet hose as shown

Note: Move the hose clamp back into its original position.



### Step 27

Connect the 1.3L air supply hose to the air cleaner case as shown.

Note: The OEM hose clamp could be used here if you feel a need.





### Step 28

This hose will likely be too long. If so, mark the hose where it will need to be cut.

Note: The hose should slide over the elbow at least 1”.



### Step 29

Cut the hose with a knife.



### Step 30

Slide the hose on the PVC elbow as shown.

Note: You could use the OEM wire type clamp here if you'd like, but it is really not necessary. This hose is a tight fit.



### Step 31

If there is a small tube, extending from the valve cover, plug it with a 5/16 vacuum cap or equivalent.

Note: If there is a vacuum hose connecting this small tube to the PCV valve, simply leave it connected.



### Step 32

Secure the hose using the existing bendable restraint on the side of 1.3L air inlet case.



### Tech Tip

The 1.3L TCAC (Thermostatically Controlled Air Cleaner) feature does not need to be operational for 1.6L fuel injected engine. Therefore, there is no need to connect a hose (or cap) to the port indicated by the arrow. (See Figure B)

This hose is not needed when adapting the 1.3 air cleaner assembly to the 1.6 Fuel Injected System.

Figure B

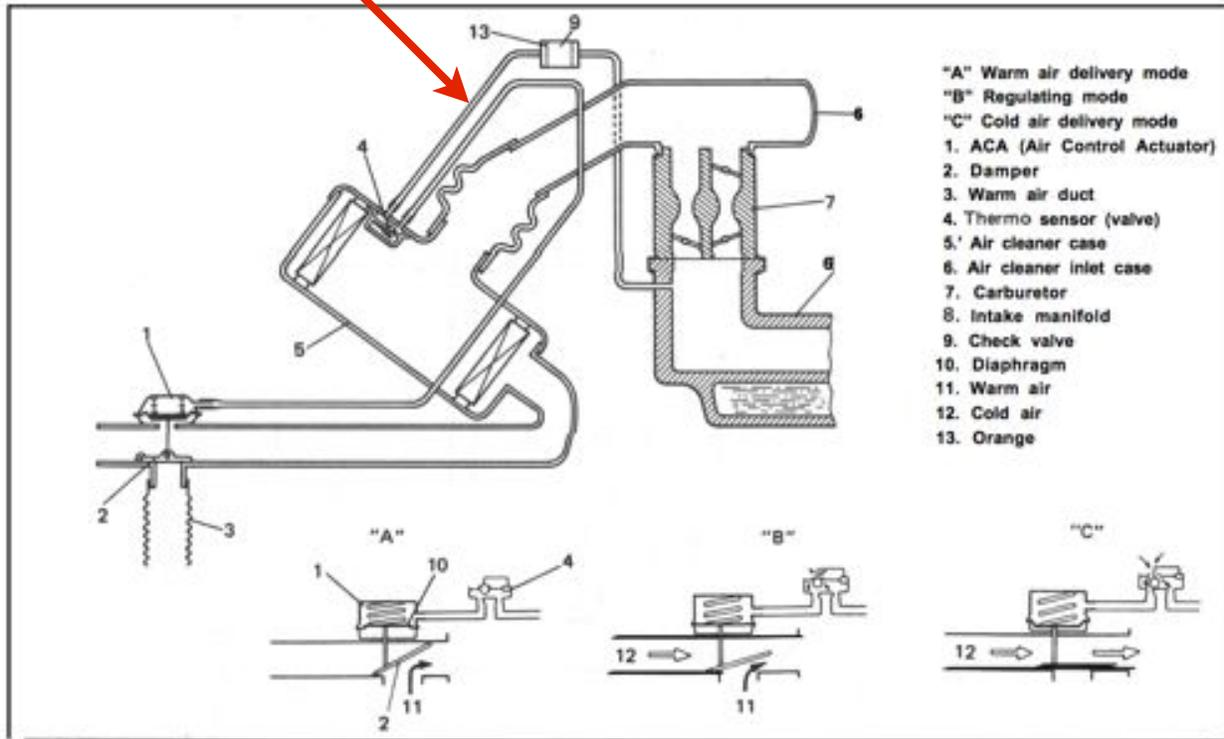

FIG. 5-1-4 TCAC system operation

1986-88.5 (Carbureted) Samurai Air Inlet

### Tech Tip

If there any open vacuum ports in the throttle body or intake manifold that will cause a vacuum leak, it is important to plug them. This will help maintain the proper air-fuel ratio for smooth engine operation.



### Step 33

You have successfully installed the 1.3L Air Intake System on a 1.6L Electronic Fuel Injected Engine.



As always, If you experience any difficulty during the installation of this product please contact Low Range Off-Road Technical Support at 801-805-6644 M-F 8am-5pm MST. Thank you for purchasing from Low Range Off-Road.



These instructions are designed as a general installation guide. Installation of many Low Range Off-Road products require specialized skills such as metal fabrication, welding and mechanical trouble shooting. If you have any questions or are unsure about how to proceed, please contact our shop at 801-805-6644 or seek help from a competent fabricator. Using fabrication tools such as welders, torches and grinders can cause serious bodily harm and death. Please operate equipment carefully and observe proper safety procedures.

Rock crawling and off-road driving are inherently dangerous activities. Some modifications will adversely affect the on-road handling characteristics of your vehicle. All products sold by Low Range Off-Road are sold for off road use only. Any other use or application is the responsibility of the purchaser and/or user. Some modifications and installation of certain aftermarket parts may under certain circumstances void your original dealer warranty. Modification of your vehicle may create dangerous conditions, which could cause roll-overs resulting in serious bodily injury or death. Buyers and users of these products hereby expressly assume all risks associated with any such modifications and use.

Revised 08/19/13© Copyright 2013 Low Range Off-Road, LC All Rights Reserved

