

Instructions Created by an:



**Automotive
Service
Excellence**
MASTER AUTO TECHNICIAN



Revised 7-11-17

LRT 2005-2017 3/1 Leveling/ Lift Kit for Toyota Tacoma by Low Range Off-Road (SKU# LR-LRTACO)

Installation Instructions



Suggested Tools:

- Twin Post Lift (or Floor Jack)
- 1 Jack Stand (if using Twin Post Lift)
- Under Hoist Jack Stand (if using Twin Post Lift)
- 2 Jack Stands (if using Floor Jack)
- 1/2" Dr Impact Wrench
- 1/2" Dr. Impact Sockets: 12,14, 17, 19, 21 & 22 mm
- 3/8" Dr Impact Wrench
- 3/8" Dr. Impact Sockets: 12,14, 17, 19, 21 & 22 mm
- Standard 3/8" Dr. Sockets: 12,14,17,19 & 22 mm
- 3/8" Dr. Allen Socket: 6mm
- 3/8" Dr. Ratchet
- 3/8 Dr. Extensions: 6, 12, and 18"
- 1/2" Dr. Torque Wrench: up to 150 Ft. Lb.
- 3/8" Dr. Torque Wrench: up to 100 Ft. Lb.
- Combination wrenches: 14,17,19 & 22mm
- Ratcheting Box End Wrench: 14 & 17mm
- Pipe Wrench 18"
- Brass Hammer
- Large Pry Bar: 24"
- Large Tapered Punch (or Lady's Foot Pry Bar)
- White (or Yellow) Metal Marker
- Ratcheting Tie-Down Strap

CAUTION: Safety glasses should be worn at all times when working with vehicles and related tools and equipment.



FOR ADDITIONAL COPIES OF THESE AND OTHER INSTRUCTIONS GO TO:
www.lowrangeoffroad.com and click on the "INSTRUCTIONS" tab.



Lady's Foot Pry Bar

Caution:

This vehicle will require a professional wheel alignment after this lift kit has been installed. Failure to have this vehicle professionally aligned could result in poor vehicle stability, handling, and braking; as well as excessive tire tread wear. Further, certain aspects of this installation can be dangerous. Therefore, we recommend that a trained professional technician install this kit.

General Note

The photographs for these instructions were taken with the vehicle placed on a twin post lift. However, this job could be done with a floor jack and jack stands. We also used power tools in our installation but, manual tools could be substituted and work reasonably well.

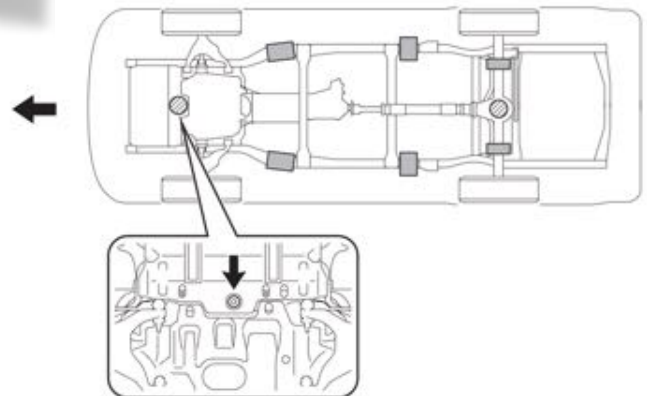

JACK POSITION

Front Center of crossmember

Rear Center of rear axle housing

CAUTION: When jacking up the front and rear, make sure the vehicle is not carrying any extra weight.

SUPPORT POSITION

Safety stand

Swing arm type lift

Step 1

Lift the vehicle on a twin post lift.

OR

Lift the front of the vehicle with a floor jack and support it with (2) jack stands. Refer to **Figure A** for proper floor jack and jack stand support positions.

Figure A

Stabilizer Bar & Shock Absorber Components

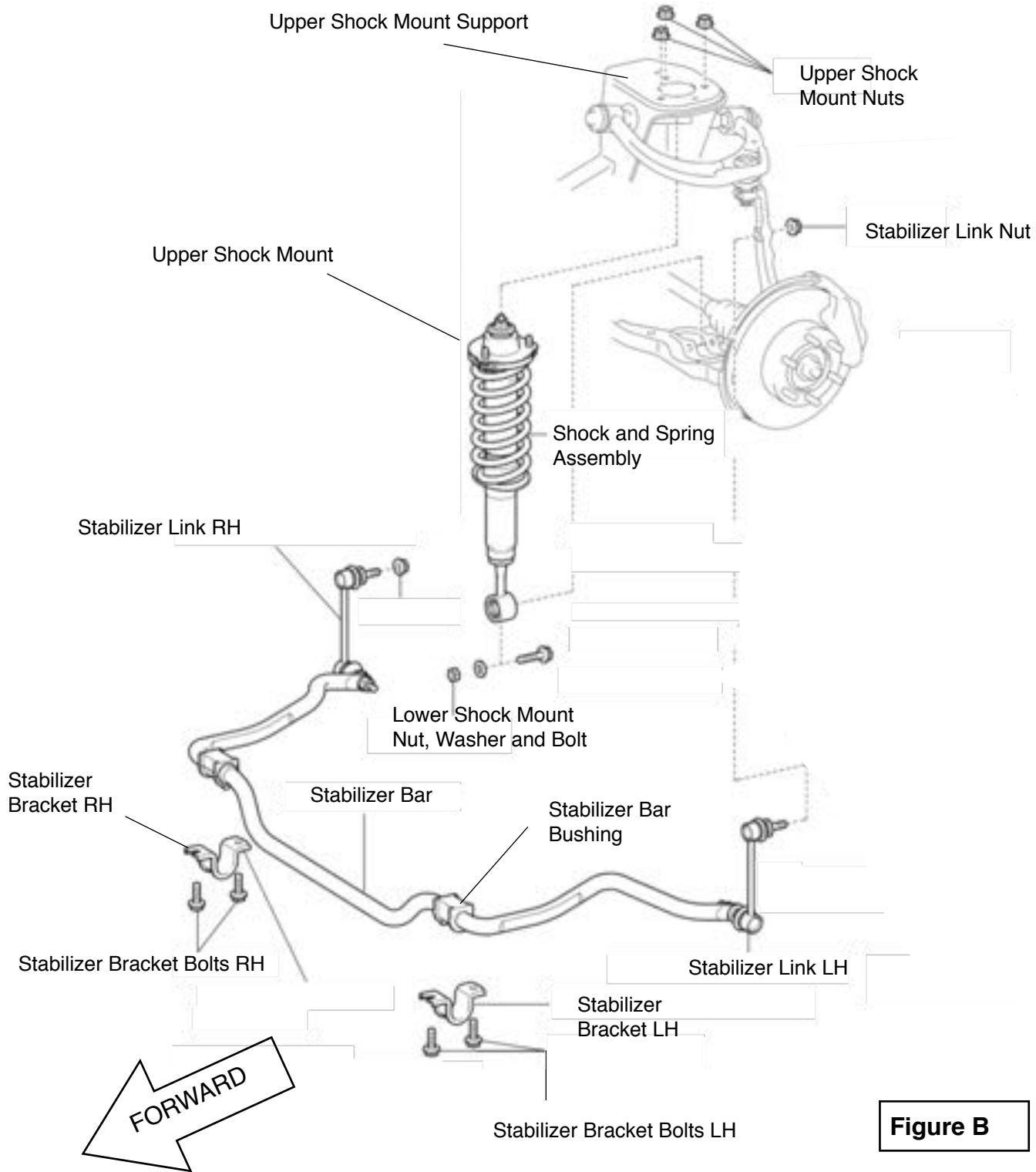
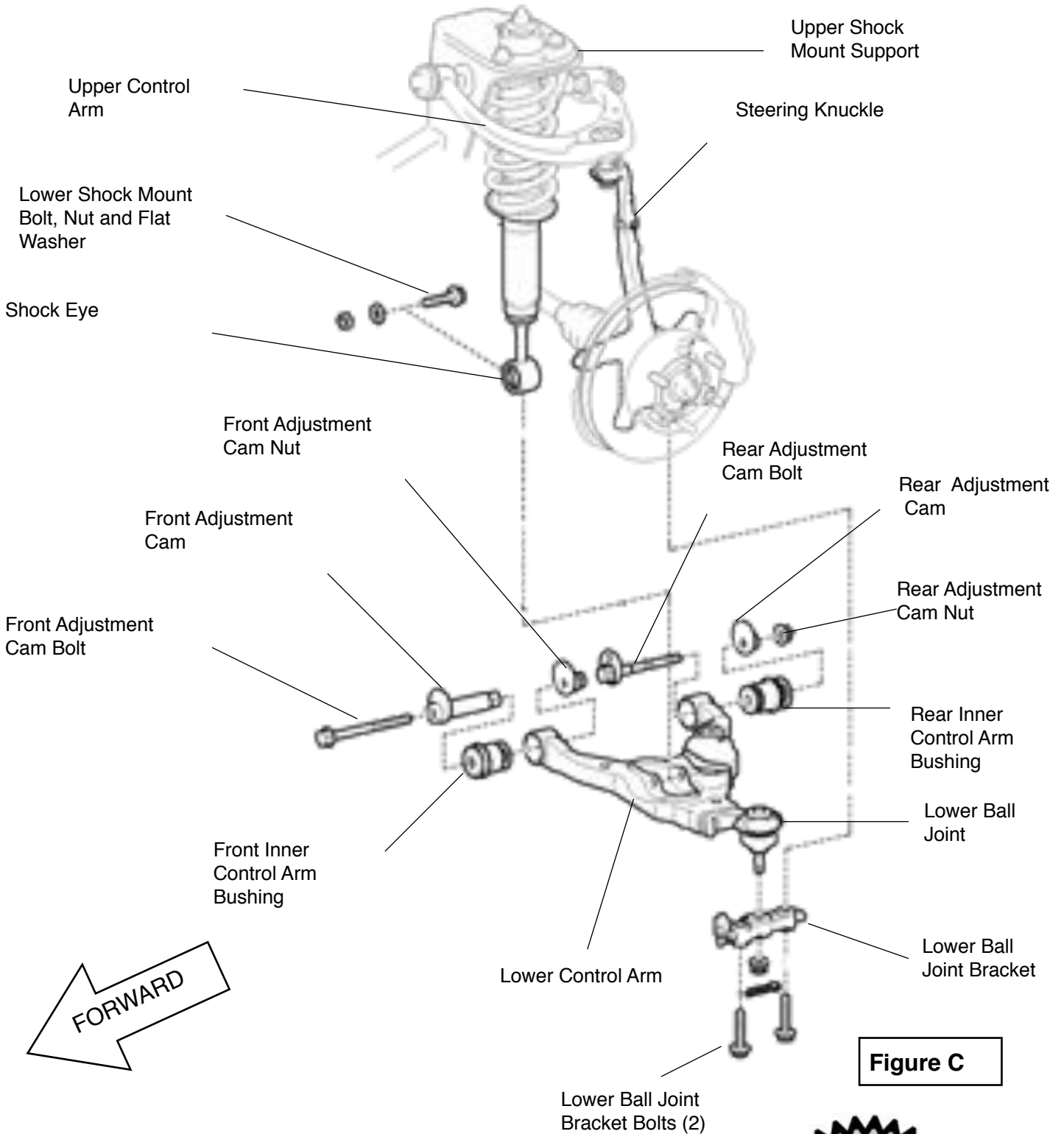

Figure B



Lower Control Arm and Related Components



Disconnecting the Stabilizer Links



Step 2

Remove the driver side front wheel assembly using a 21mm socket. Set the wheel assembly aside.



Step 3

Disconnect the driver side stabilizer link from the steering knuckle using a 17mm socket.



Tech Tip 3A

It may be necessary to tap the link stud from the knuckle using a brass hammer.

Caution: Be careful not to damage the threads of the stud.



Tech Tip 3B

In some cases it may be necessary to hold the stabilizer stud with a 6mm allen socket and turn the nut with a 17mm ratcheting box end wrench.





Step 4

Lay the stabilizer link back out of the way.



Step 5

Remove the passenger side front wheel and set it aside.



Step 6

Disconnect the passenger side stabilizer link following the same procedure used on the driver side.

Disconnecting the Driver Side Lower Shock Mount



Step 7

Hold the nut using a 19mm combination wrench.



Step 8

Remove the nut by turning the bolt using a 19mm socket. Leave the bolt in place for now.

Note: It would probably be better to hold the bolt and remove the nut but we found it difficult to get a tool on the bolt.

Skid Plate Components

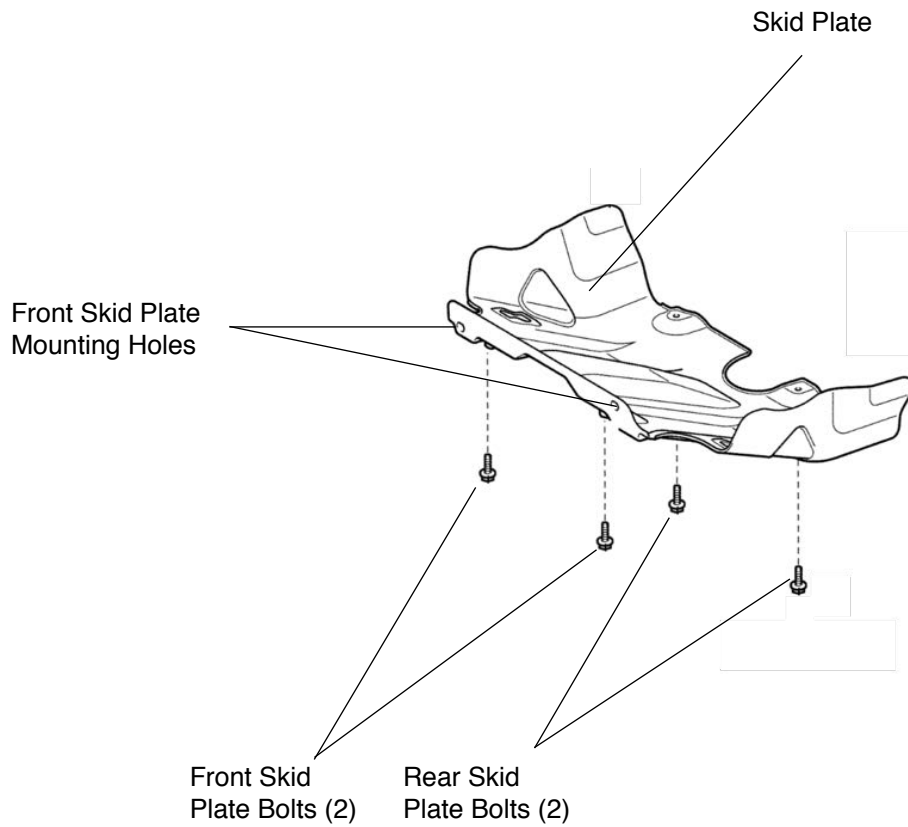

Figure D



Removing the Skid Plate



Step 9

Remove all 4 of the skid plate mounting bolts using a 12mm socket.

Note: These bolts can be discarded. They will be replaced with longer ones supplied in the kit.

Step 10

Once all 4 bolts have been removed, lower the rear of the plate and unhook it from the front by lifting and pushing the plate forward. See next Tech Tip

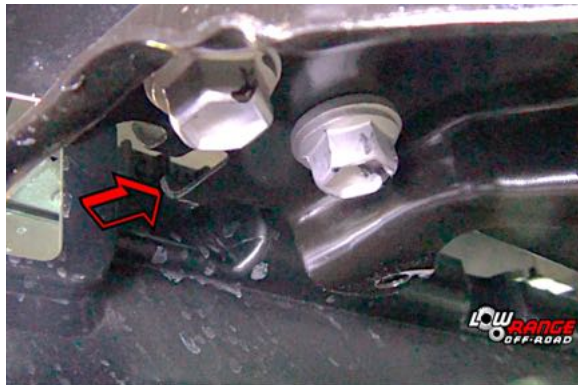

Tech Tip 10A

The skid plate is attached at the front by two hooks like the one shown here.

Tech Tip 10B

This skid plate is attached at the front by two mounting holes like the one shown here.



Marking the Alignment Cams

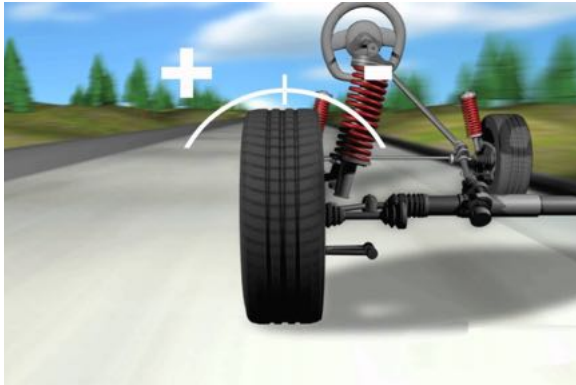

Important Note

Marking the position of the alignment cams will help restore the cams as close as possible to their original settings. Thus somewhat maintaining Caster, Camber and Toe settings. This vehicle will still require an expert alignment after the lift kit has been installed, but will maintain alignment settings as close as possible so you can drive to the alignment shop with minimal tire wear. Be aware that until this vehicle has been professionally aligned you may experience unusual braking, handling, ride, and excessive tread wear.

Step 11

Using a white permanent marker, mark the cam and the frame as shown here.



Step 12

Mark the other (3) alignment cams in the same way.

Removing the Shock Absorber & Coil Spring Assembly



Step 13

Beginning on the driver side, LOOSEN the front alignment cam bolt using a 22 mm box end wrench.

Note: LOOSEN, do not remove this bolt. Also, this bolt can be very difficult to move, especially if a lot of rust is present. It may be necessary to use a socket and breaker bar or an impact wrench to break this bolt loose. Applying penetrating oil is also helpful.

Caution: If Penetrating oil is used, avoid applying it to the rubber part of the inner control arm bushings as much as possible.



Step 14

LOOSEN the rear alignment cam nut using a 22mm box end wrench.

Note: See the Note in the previous step for tips on how to loosen this nut.



Step 15

Begin disconnecting the lower ball joint bracket by removing the front ball joint bracket bolt using a 19mm socket.



Step 16

Remove the rear ball joint bracket bolt.



Step 17

While supporting the lower control arm, remove the lower shock mount bolt by tapping it out with a brass hammer.

Caution: Be careful not to damage the threads on the lower shock mount bolt.



Step 18

Let the lower control arm swing down out of the way. If the lower control arm does not swing down out of the way relatively easily, try loosening the adjustment cam bolt and nut a little more.



Tech Tip 18

In some cases, if a lot of rust is present, it may be necessary to force the lower control arm to swing down.



Step 19

Remove the **REAR** upper strut mount nut using a 14mm socket.



Step 20

LOOSEN (only loosen) the front upper shock mount nut.



Step 21

Remove the inside upper shock mount nut using a 14mm ratcheting box end wrench.

Note: You may be able to remove this nut from under the hood using a socket and an extension.



Step 22

Support the shock with one hand and



Step 23

. . . remove the front upper strut mount nut with the other hand



Step 24

. . . and guide the shock and spring assembly out the bottom as shown.

Installing the Shock Mount Spacer

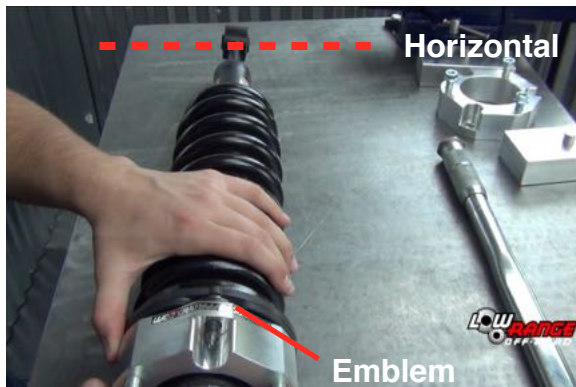

Step 25

Place the shock and spring assembly on a work bench with the lower shock mount eye in the horizontal position. Position the supplied spacer on top of the assembly with the lowrangeoffroad.com emblem oriented upward.



Step 26

Install the (3) supplied serrated flange nuts on the spacer studs.



Step 27

Snug all three serrated flange nuts using a 14mm socket.



Step 28

Secure the shock and spring assembly using a bar to keep it from turning while torquing the 3 serrated flange nuts.



Step 29

Torque the nuts in a progressively tighter criss-cross pattern until 47ft. lbs. is reached.

Installing the Shock and Spring Assembly



Step 30

Swing the hub, axle and knuckle assembly rearward to give greater space for the shock and spring assembly.

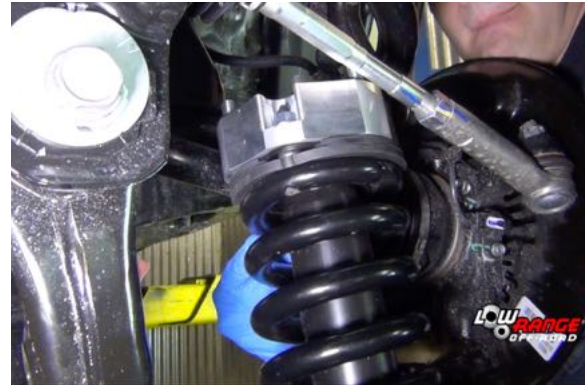

Step 31

Feed the shock and spring assembly up into position.



Step 32

Align the spacer studs with the upper shock mount support.

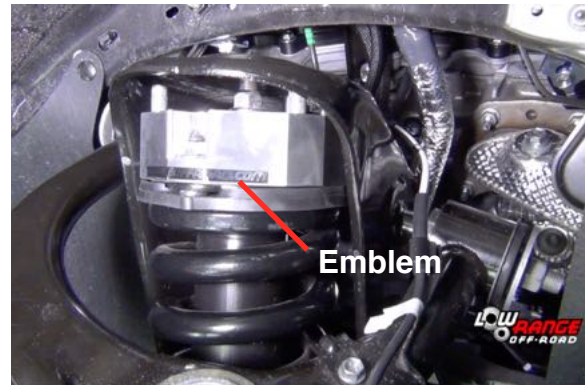

Tech Tip 32

Be sure the lowrangeoffroad.com emblem is oriented outward, or away from the engine.





Step 33

Install the (3) supplied serrated flange nuts.



Step 34

Snug all three nuts using a 14mm socket.



Step 35

Torque all three nuts in a progressively tighter criss-cross pattern until 47 ft. lbs is reached.

Note: You may need to torque the inside nut from under the hood using an extension or you could simply estimate the torque using a box end wrench.



Step 36

Swing the lower control arm up into position and align the lower shock eye with the lower shock mount.



Tech Tip 36

This shows the lower shock mount properly aligned. You may need to use a tapered punch or the tapered end of a ladies foot pry bar to align these holes.



Step 37

Insert the bolt from the rear and install the washer and . . .



Step 38

. . . the nut.



Step 39

While holding the bolt from the rear, torque the nut to 61 ft. lbs.



Reconnecting the Lower Ball Joint Bracket



Step 40

Loop a ratchet strap around the front of the upper control arm . . .



Step 40 Continued

. . . and the lower control arm,



Step 40 Continued

. . . and connect the two ratchet strap hooks. (See Figure F)

Ratchet Strap Routing

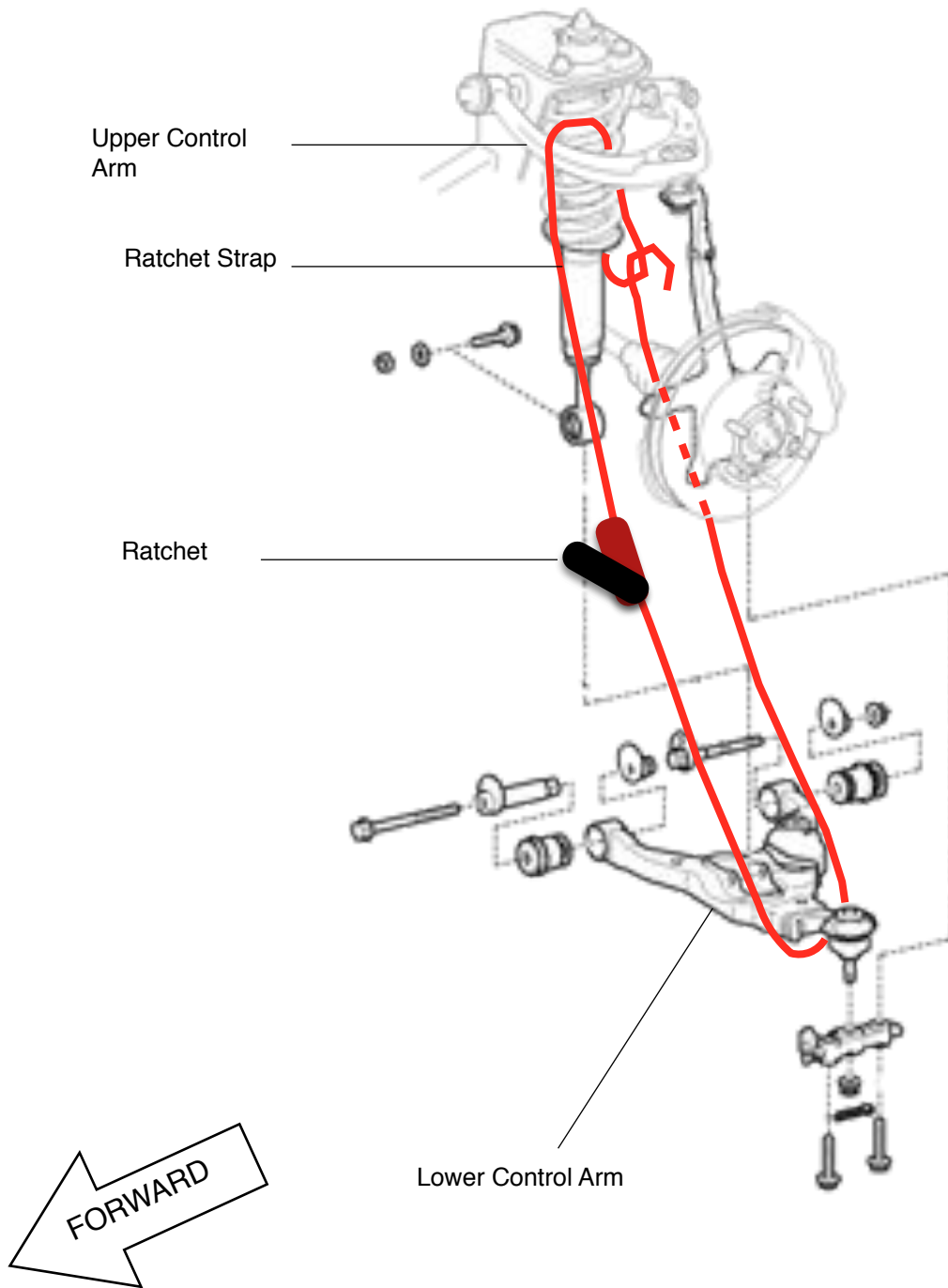

Figure E





Step 41

Once the ratchet strap is secured, tighten it . . .

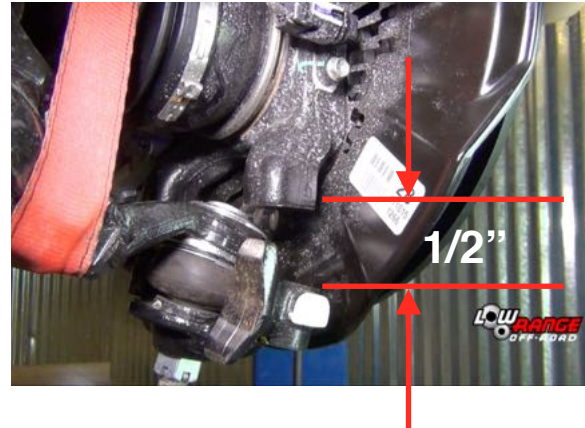

Step 42

. . . until there is about a 1/2" between the lower ball joint bracket and the steering knuckle.

Note: The gap shown here is about 1-1/2". If the gap closes to 1/2" with the ratchet strap, skip to Step 44. If not, continue to Step 43.



Step 43

It may be necessary to place a jack stand (or floor jack) under the lower control arm to close the gap to 1/2" between the lower ball joint bracket and the steering knuckle.



Step 44

Once the ball joint bracket is within 1/2" of the steering knuckle, apply some red treadlocker to one of the lower ball joint bracket bolts and . . .



Step 45

... START the bolt by hand. Be careful not to cross-thread this bolt. Once you are sure the bolt is STARTED correctly, go to the next step.



Step 46

Tighten the bolt until there is about 1/4" between the ball joint bracket and the steering knuckle.



Step 47

START the rear bolt being extra careful not to cross-thread.



Step 48

Once the rear bolt is correctly started, tighten it until there is no gap between the lower ball joint bracket and the steering knuckle.

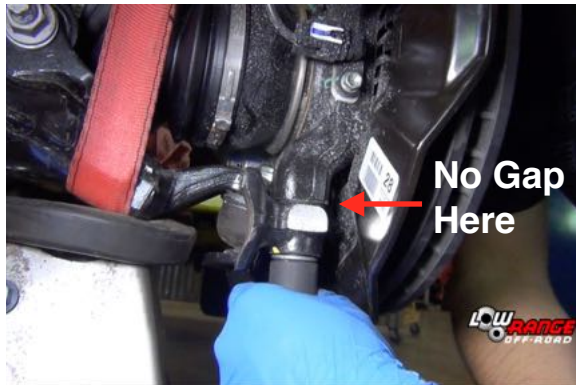

Step 49

Tighten the front bolt until there is no gap between the ball joint bracket and the steering knuckle.



Step 50

Once both ball joint brackets bolts are started and snug, raise the vehicle off the jack stand (or remove the floor jack).

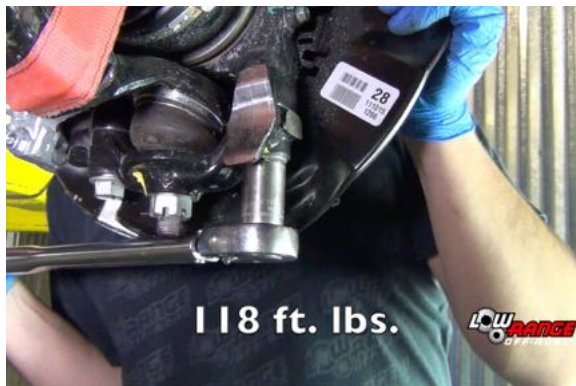

Step 51

Tighten the ball joint bracket bolts in a progressively tighter, back and forth method, until 118 ft. lbs. is reached.



Step 52

Release and remove the ratchet strap.

Installing the Spacer on the Passenger Side Shock and Spring Assembly



Step 53

Repeat Steps 13 through 52 on the passenger side shock and spring assembly.

Reconnecting the Stabilizer links



Step 54

Insert the passenger side stabilizer link stud into the steering knuckle.



Step 55

Install the nut.



Step 56

While holding the stud with a 6mm allen socket, tighten the nut using a ratcheting box end wrench. Once the nut is snug go on to the next step.



Step 57

Tighten the nut until 52 ft. lbs. is reached.



Step 58

Connect the driver side stabilizer link using the same procedure followed on the passenger side.

Installing the Bump Stop Spacers



Step 59

Unthread the passenger side bump stop using a pipe wrench.



Step 60

Apply blue threadlocker to the threads of the stud.



Step 61

Install the supplied spacer over the stud.



Step 62

Reinstall the bump stop.



Step 63

Tighten the bump stop with the pipe wrench.



Step 64

Install the driver side bump stop spacer following the same procedure used on the passenger side.

Front Differential Assembly Components

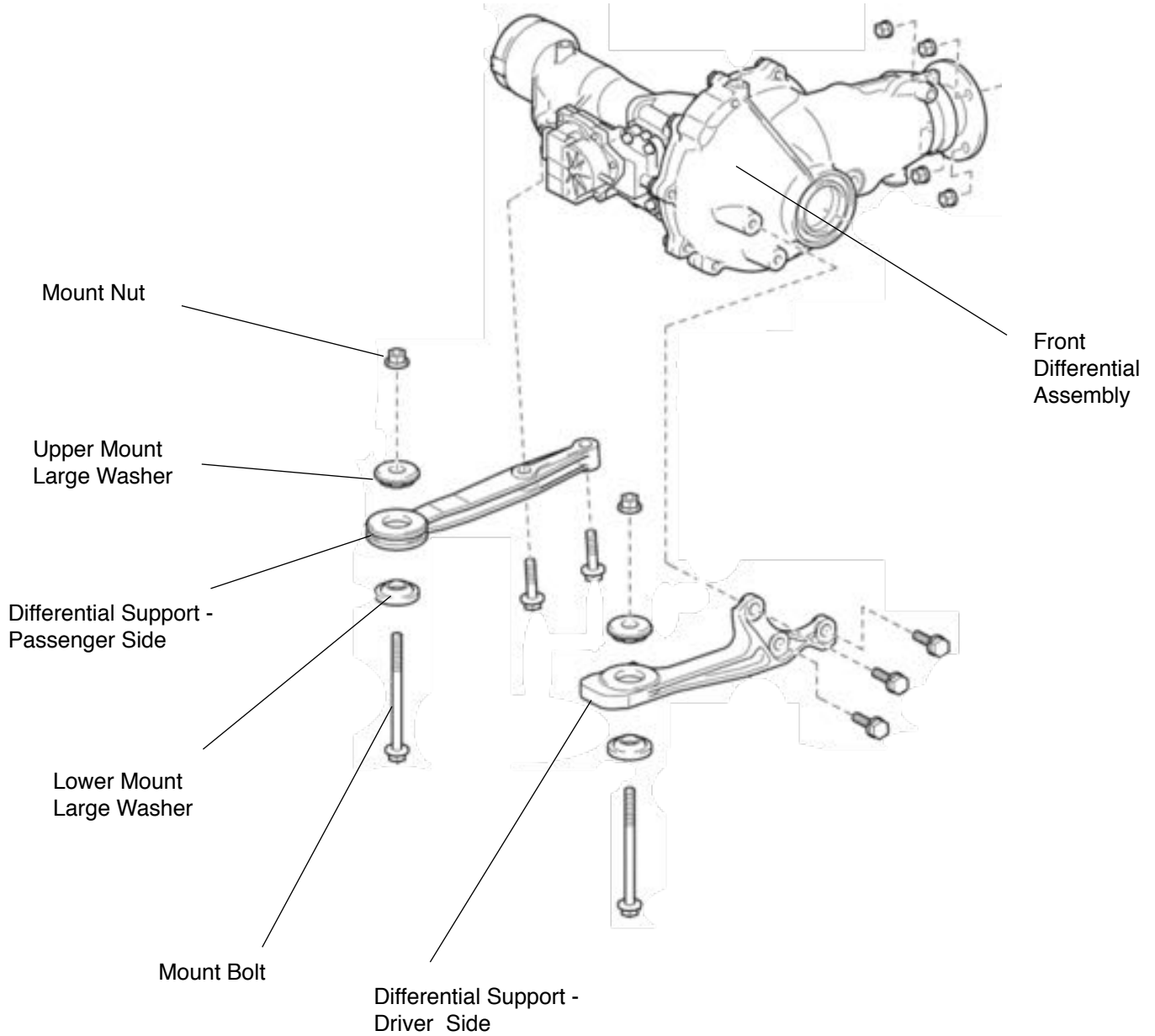

Figure F



Installing the Differential Drop Spacers



Step 65

While holding the nut with a 19mm box end wrench, remove the passenger side differential mount bolt using a 22mm socket. This bolt and nut will NOT be reused. However, the lower and upper mount large washers will be reused.



Step 66

Remove the passenger side differential mount bolt using in the same method. The differential support should drop down enough (a little more than 1") on its own to provide enough space for the supplied spacers. If it does not, you will need pry down on the differential supports using a pry bar.



Step 67

Ready the supplied longer mount bolt by installing the supplied flat washer.



Step 68

Then install the lower mount large washer that was removed earlier.



Step 69

Place a supplied spacer between the upper mount larger washer and the frame and install the supplied bolt as shown.



Step 70

Install the supplied flange nut on the top of the bolt. Just start the nut for now. **DO NOT** tighten it yet.



Step 71

Install the driver side supplied bolt, flat washer, spacer and nut using the same procedure as the passenger side.



Step 72

While holding the nut with a 19mm box end wrench, snug both differential mount bolts using a 19mm socket.



Step 73

While continuing to hold the nut, torque the passenger side bolt to 101 ft. lbs.

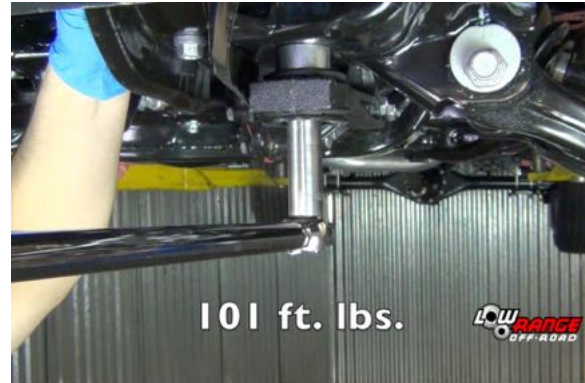

Step 74

Torque the driver side bolt to using the same method.



Step 75

Position all 4 of the alignment cams in the same position as they were before this installation. (See Step 11)



Step 76

Position the driver side front wheel on the wheel studs and snug the lug nuts.



Step 77

Install the passenger side wheel assembly and snug the lug nuts.



Step 78

Lower the hoist until the tires begin to press against the floor.



Step 79

Tighten the lug nuts in an increasingly tighter criss-cross pattern until 81ft. lbs is reached.

Note: This torque spec varies from vehicle to vehicle. To be sure of the correct specification check the owners manual for the specification that matches your vehicle.



Step 80

Continue lowering the hoist until all the weight of the vehicle is being supported by the wheels.



Step 81

Bounce the front of the vehicle up and down to insure the vehicle is at it's normal ride height.



Step 82

Double check to see that all 4 of the alignment cams are still positioned correctly.



Step 83

Torque all 4 of the alignment cams to 100 ft. lbs. Insure that the cams stay positioned correctly while torquing.

Installing the Skid Plate



Step 84

Hook the front of the skid plate on the (2) hooks and let it hang for now.

Step 85

Obtain the (4) supplied bolts and spacers. The spacers are to be installed on top the skid plate and the bolt inserted from below at all 4 locations.

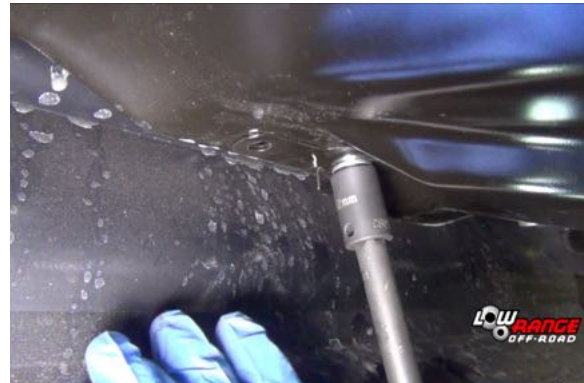

Step 86

While holding the spacer on top of the skid plate, insert the bolt from the bottom and start the bolt in the threaded hole. Begin by installing the front two bolts and spacers and then the two bolts and spacers in the rear.

Step 87

After all (4) bolts are started, snug them using a 12 mm socket.

Note: Some people have found it helpful to “glue” the front spaces in place using Permatex Gasket Maker before installing the skid plate.

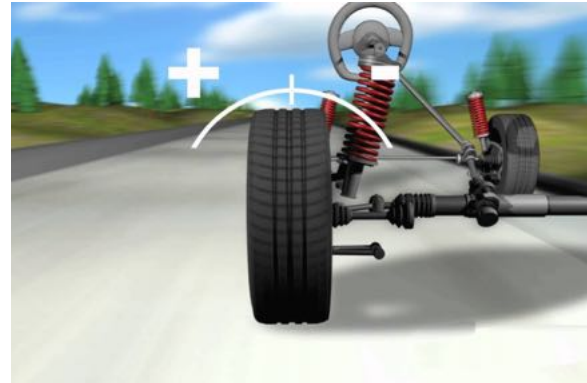

Step 88

Then torque all (4) bolts to 20 ft. lbs.

IMPORTANT

This is just a friendly reminder that this vehicle will require a professional wheel alignment after this kit has been installed. Failure to have this vehicle professionally aligned could result in poor vehicle stability, handling, and braking; as well as excessive tire tread wear. Therefore, we recommend that this vehicle be aligned as soon as possible after completing this installation.



Rear Axle Assembly & Leaf Spring Components

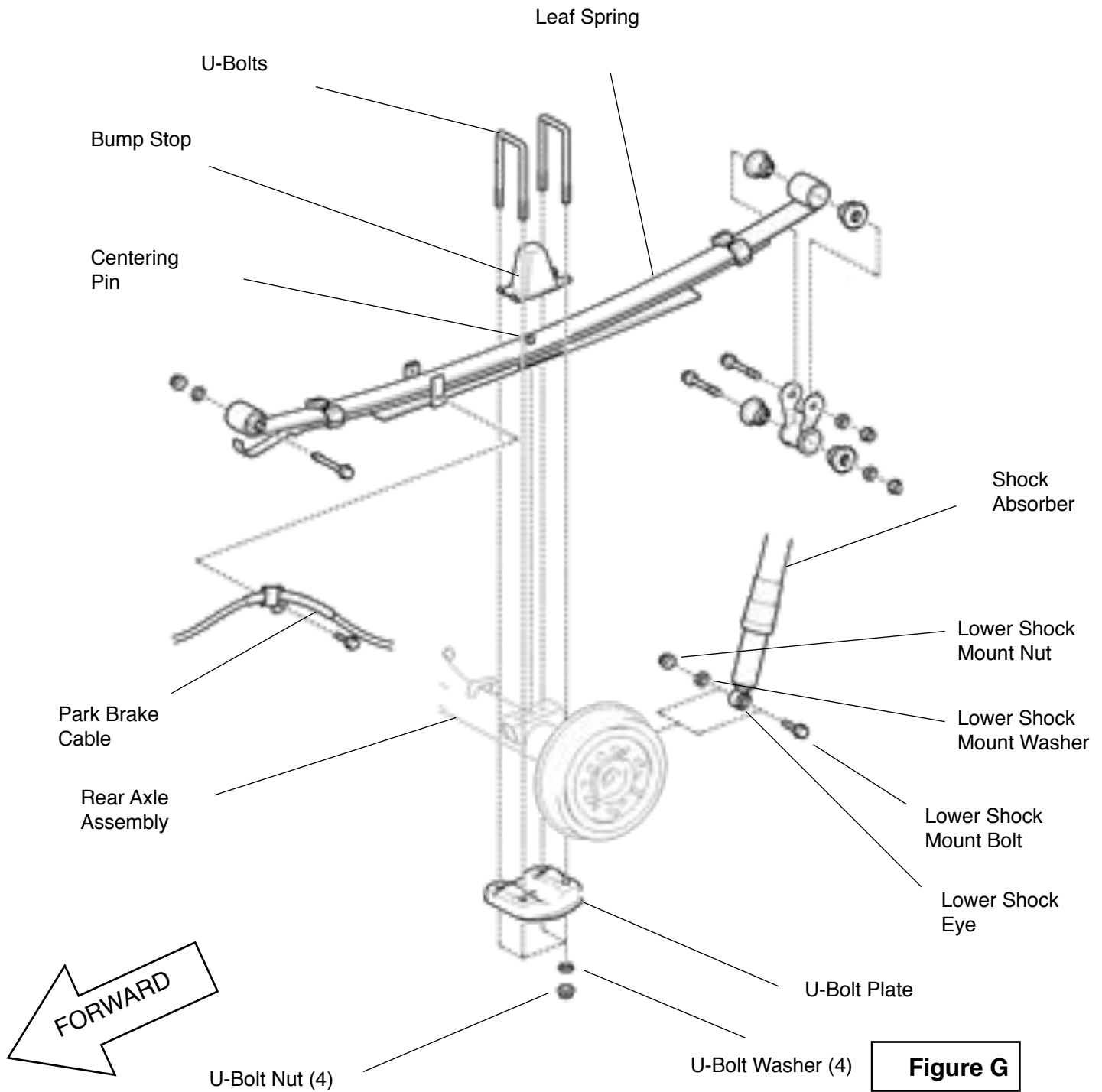

Installing the Rear Spacer Blocks – Driver Side



Step 89

Place an under hoist jack stand under the driver side of the rear axle assembly and raise it up lightly. Just enough so the rear axle assembly is not being suspended by the shock absorber.

Step 90

Remove the U-bolt nuts and washers using a 19mm socket.



Step 91

Remove the U-bolt plate.

Step 92

Remove the (2) U-bolts.



Step 93

Leave the bump stop in place.



Step 94

Disconnect the lower shock mount by holding the bolt with a 17mm box end wrench and removing the nut and washer using a 17mm socket.

Note: Keep track of this bolt, washer and nut. It will be needed later.



Step 95

With the lower shock mount disconnected, lower the rear axle housing by lowering the under hoist jack stand.



Step 96

Continue lowering the rear axle housing until there is enough space for the supplied spacer block.

Note: ***DO NOT*** lower the rear axle housing any more than is necessary to install the spacer. The park brake cable could be damaged.



Step 97

Install the supplied spacer. See the next Tech Tip for proper spacer orientation.

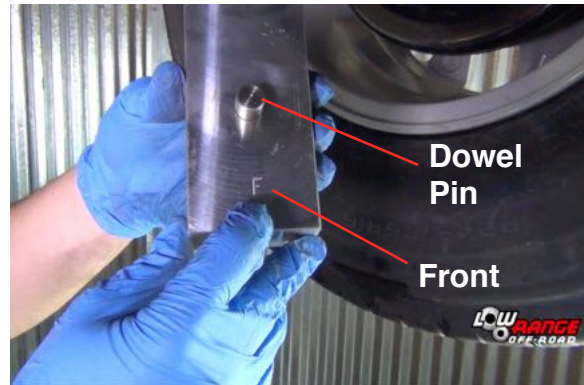

Tech Tip 97

The spacer is to be installed with the “F” oriented toward the front of the vehicle and dowel pin facing downward.



Step 98

With the spacer in place, raise the rear axle housing back into position.



Step 99

Guide the leaf spring centering pin into the hole in the spacer. The gap between the spring and the block must be completely eliminated for proper fitment. Furthermore, there should be not gap between the spacer and the spring perch. If these parts, above and below the spacer, do not come completely together, separate the parts and do whatever necessary such that they will.



Tech Tip 99

This shows the leaf spring and the block properly fitted together with no gaps above or below the spacer.



Step 100

Install the supplied rear U-Bolt.

Note: Be sure the bump stop is in position to be secured by the U-Bolt.



Step 101

Install the supplied front U-Bolt.



Step 102

Install the U-Bolt plate.



Step 103

Install the (4) Supplied U-Bolt washers and (4) supplied U-Bolt Nuts. Snug the nuts in an increasing tighter criss-cross pattern. Just snug is enough for now.



Step 104

Raise the rear axle housing with the under hoist jack stand . . .



Step 105

. . . and position the shock absorber eye in the lower shock mount and align the holes.



Step 106

Install the lower shock mount bolt.



Step 107

Install the washer . . .



Step 108

. . . and the nut. Leave the nut snug for now. We will torque it later.



Step 109

Remove the under hoist jack stand from the driver side rear axle housing.

Installing the Rear Spacer Blocks – Passenger Side



Step 110

Place the under hoist jack stand under the passenger side axle assembly.



Step 111

Install the passenger side spacer, U-bolts, U-Bolt washers and U-Bolt nuts following the same instructions used on the driver side.

Torquing All The Nuts At The Rear Axle Assembly



Step 112

Tighten the (4) passenger side U-Bolt nuts in an increasingly tighter criss-cross pattern until 100 ft. lbs. is reached.

Note: This will take a lot of tightening due to the stretch in the U-Bolts and the flex of the U-Bolt plate.



Step 113

Tighten the lower shock mount nuts to 43 ft. lbs.



Step 114

Tighten the driver side U-Bolts using the same procedure as you followed on the passenger side.



Step 115

Tighten the lower shock mount nut to 43 ft. lbs.



Step 116

Before lowering the vehicle we recommend checking to see that all the nuts and bolts are tightened to the correct torque and that all the brake lines, electrical wiring, park brake cables and all similar associated components are routed correctly and are secure. We also strongly recommend that this vehicle be professionally aligned as soon as possible after the installation of



Step 117

Lower the vehicle.



Congratulations!

You have successfully installed a Tacoma LRT 3 to 1 Leveling Lift Kit. We hope these instructions have been helpful. If you have suggestions on how to make these instructions (or products) better, please email us at: sales@lowrangeoffroad.com



As always, If you experience any difficulty during the installation of this product please contact Low Range Off-Road Technical Support at 801-805-6644 M-F 7:30am-5:30pm MST. Thank you for purchasing from Low Range Off-Road.



These instructions are designed as a general installation guide. Installation of many Low Range Off-Road products require specialized skills such as metal fabrication, welding and mechanical trouble shooting. If you have any questions or are unsure about how to proceed, please contact our shop at 801-805-6644 or seek help from a competent fabricator. Using fabrication tools such as welders, torches and grinders can cause serious bodily harm and death. Please operate equipment carefully and observe proper safety procedures.

Rock crawling and off-road driving are inherently dangerous activities. Some modifications will adversely affect the on-road handling characteristics of your vehicle. All products sold by Low Range Off-Road are sold for off road use only. Any other use or application is the responsibility of the purchaser and/or user. Some modifications and installation of certain aftermarket parts may under certain circumstances void your original dealer warranty. Modification of your vehicle may create dangerous conditions, which could cause roll-overs resulting in serious bodily injury or death. Buyers and users of these products hereby expressly assume all risks associated with any such modifications and use.

Revised 09/01/16© Copyright 2016 Low Range Off-Road, LC All Rights Reserved

