

JEEP GLADIATOR 2019 – 20XX

ROCKER GUARD INSTALLATION INSTRUCTIONS



SAFETY

Know Safety, no injury. Know injury, no safety. ~Author Unknown

If there are any questions, call 1-855-HHTOUGH

- **READ ALL SAFETY INSTRUCTIONS BEFORE INSTALLATION**
 - FOLLOW ALL INSTRUCTIONS FOR PROPER ASSEMBLY
 - WEAR APPROPRIATE EYE PROTECTION
 - EXERCISE CARE WHEN LIFTING COMPONENTS
 - USE APPROPRIATE TORQUE FOR BOLTS
 - BLUE THREAD LOCKING COMPOUND IS RECOMMENDED ON ALL BOLTS

SUGGESTED TORQUE VALUES FOR STEEL GRADE SAE 5 BOLTS

| BOLT DIAMETER (INCH) | TREADS PER INCH | TORQUE (POUND-FEET) |
|-------------------------|-----------------|------------------------|
| 1/4 | 20 | 7 |
| 5/16 | 18 | 14 |
| 3/8 | 16 | 25 |
| 7/16 | 14 | 40 |
| 1/2 | 13 | 60 |
| 9/16 | 12 | 88 |
| 5/8 | 11 | 120 |
| 3/4 | 10 | 200 |
| 7/8 | 9 | 302 |
| 1 | 8 | 466 |



600-56-0944

I. PARTS LIST

| ITEM NO. | QTY. | PART NUMBER | DESCRIPTION |
|----------|------|-------------|-------------------------|
| 1 | 1 | 601-56-3744 | 3048MM LENGTH FOAM ROLL |
| 2 | 1 | 601-56-4590 | LEFT ROCKER GUARD |
| 3 | 1 | 601-56-4591 | RIGHT ROCKER GUARD |
| 4 | 1 | 60K-56-0196 | HARDWARE KIT #196 |

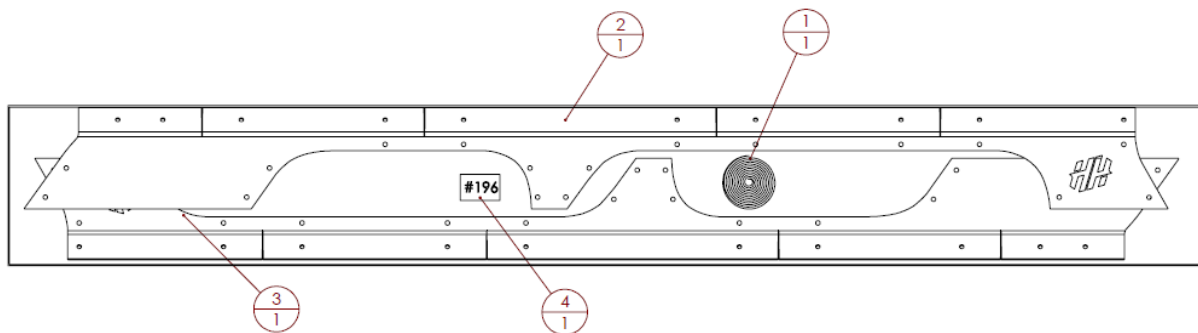

REMOVE CONTENTS FROM BOX AND VERIFY ALL PARTS ARE PRESENT.

If there are any questions, call 1-855 HHTOUGH or email HHORDERS@hammerheadarmor.com

II. TOOL LIST

1. Two Good Friends
2. Basic Tool Kit
3. Torx 30 socket
4. Center punch
5. 1/8" drill bit
6. Step drill bit (goes to 25/64")
7. 25/64" drill bit
8. Nutsert installation tool
9. Transfer punch (21/64")

III. VEHICLE PREPARATION

1. Park the Jeep on level surface and engage parking brake.
2. Remove any existing running boards from your Jeep

IV. ROCKER GUARD INSTALLATION

1. Install the foam on the back of the Rocker Guard as shown. This will protect the paint of your Jeep.

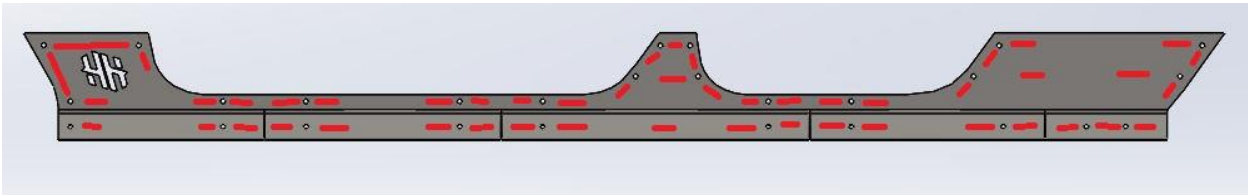

2. Have one person on each end hold the Rocker Guard up to the Jeep. Align it to your liking and transfer punch a hole on each end of the Rocker Guard as shown, then set it aside. (magnets work well for holding it in place and aligning it as well)

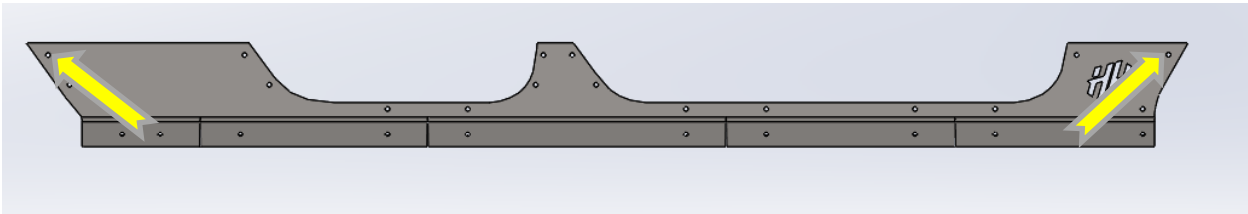

3. Using the 1/8" drill bit drill a hole at the two center punch locations, then use a step bit to enlarge the hole to 25/64".
4. Install a provided nutsert in each hole.
5. Using the provided 6mm Torx 30 bolts install the Rocker Guard on the Jeep at the 2 complete locations. Align to your liking, tighten the bolts, and center punch the other 20 holes.
6. Remove the Rocker Guard and repeat steps 3 and 4 for the other 20 hole locations as shown.

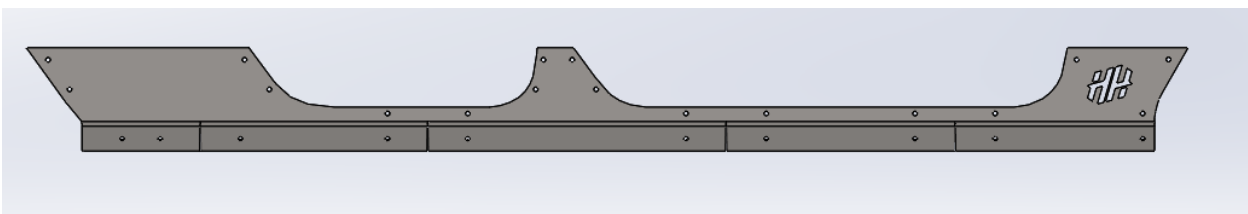

7. Reinstall the Rocker Guard using the provided 6mm Torx 30 bolts. Make sure to start EVERY BOLT then tighten down to 7lb/ft of torque.
8. Repeat for the other side.



600-56-0944



**Congratulations! Your Installation is now complete.
Thank You for your purchase!**