

2019-20XX JEEP GLADIATOR

BOTTOM TRIM INSTALLATION INSTRUCTIONS



SAFETY

Know safety, no injury. Know injury, no safety. ~Author Unknown

If there are any questions, call 1-855-HHTOUGH

- **READ ALL SAFETY INSTRUCTIONS BEFORE INSTALLATION**
 - FOLLOW ALL INSTRUCTIONS FOR PROPER ASSEMBLY
 - WEAR APPROPRIATE EYE PROTECTION
 - EXERCISE CARE WHEN LIFTING COMPONENTS
 - USE APPROPRIATE TORQUE FOR BOLTS
 - BLUE THREAD LOCKING COMPOUND IS RECOMMENDED ON ALL BOLTS

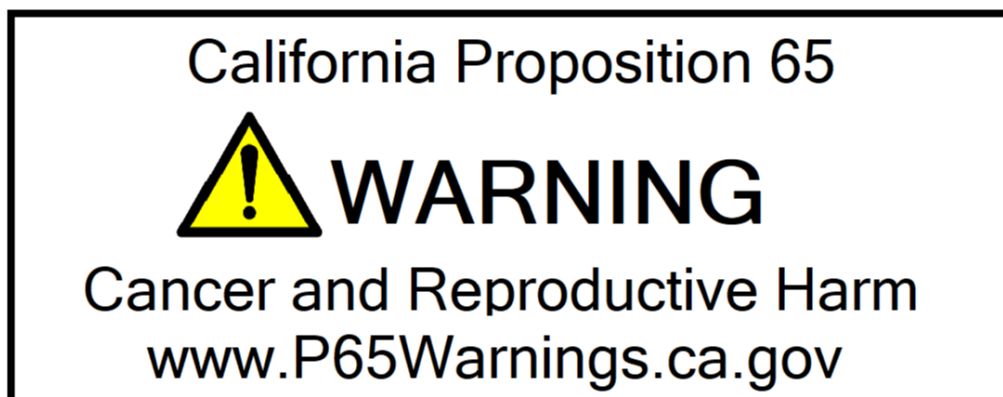

DO NOT PAINT OVER THIS LABEL. REPLACE IF DAMAGED OR LOST

DKB150_00



2019-20XX JEEP GLADIATOR

600-56-0943

Suggested Torque Values For Steel Grade 5 Standard Bolts		
BOLT DIAMETER (INCH)	THREADS PER INCH	TORQUE (POUND - FEET)
1/4	20	7
5/16	18	14
3/8	16	25
7/16	14	40
1/2	13	60
9/16	12	88
5/8	11	120
3/4	10	200
7/8	9	302
1	8	466

Suggested Torque Values For Steel Grade 8.8 Metric Bolts		
BOLT DIAMETER (mm)	THREAD PITCH (mm)	TORQUE (POUND-FEET)
6	1.0	7
8	1.25	16
10	1.5	32
12	1.75	55
14	2.0	88
16	2.0	140
18	2.5	195
20	2.5	275
22	2.5	375
24	3.0	475



2019-20XX JEEP GLADIATOR

600-56-0943

I. PARTS LIST

ITEM NO.	QTY	PART NUMBER	DESCRIPTION
1	1	601-56-3744	3048MM LENGTH FOAM ROLL
2	2	601-56-4589	TRIM PIECE 2
3	2	601-56-4830	TRIM PIECE 1
4	1	60K-56-0195	HARDWARE KIT #195

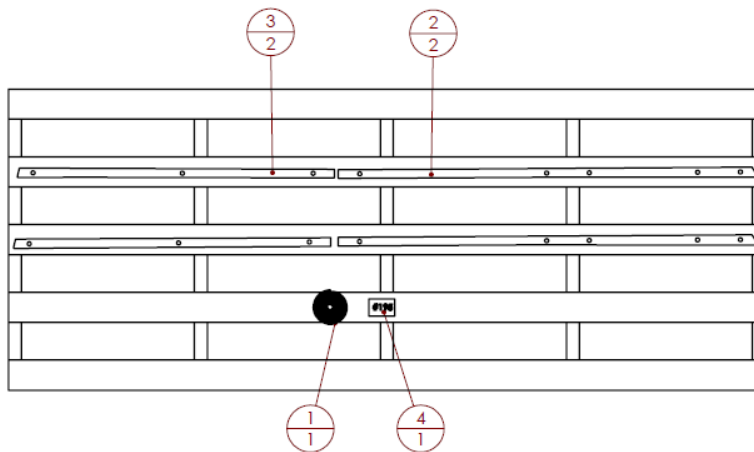

REMOVE CONTENTS FROM BOX AND VERIFY ALL PARTS ARE PRESENT.

**If there are any questions, call 1-855-HHTOUGH or email
HHORDERS@hammerheadarmor.com**

II. TOOL LIST

1. A good friend
2. Basic tool kit
3. 10mm socket
4. Torx 40
5. Torx 20
6. 13mm wrench
7. 7/16 socket
8. 7/16 wrench



III. VEHICLE PREPARATION

1. Remove any already installed rock rails or running boards
2. Remove the 2 bolts holding the front fender to the pinch seam using the 10mm socket

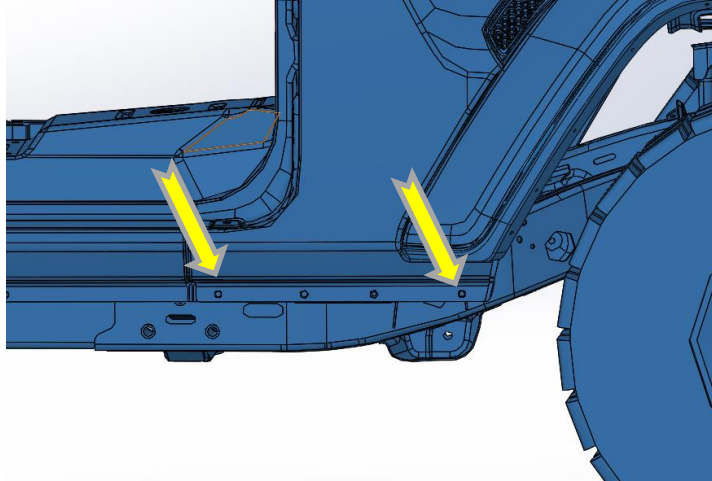

IV. PREPPING THE BOTTOM TRIM FOR INSTALL

1. Install the provided foam on the back of the Bottom Trim.
2. Place the Bottom trim on the Jeep as shown below. Spaced out holes go toward the front of the Jeep.
3. Using a Torx 30 install the two provided 6mm black bolts and washers in the locations shown below

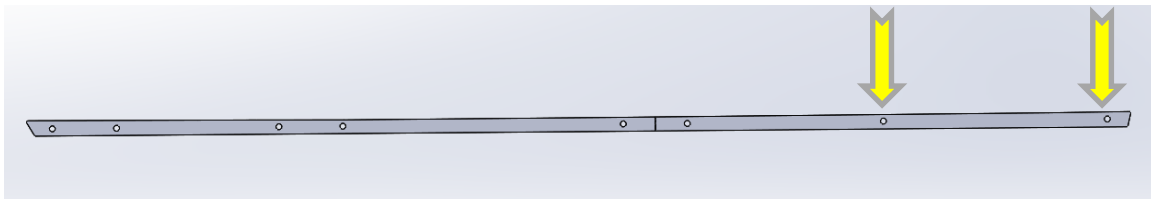

4. Using the Torx 40 and the 13mm wrench install the six provided 8mm bolts, washers, and nylock nuts in the locations shown below

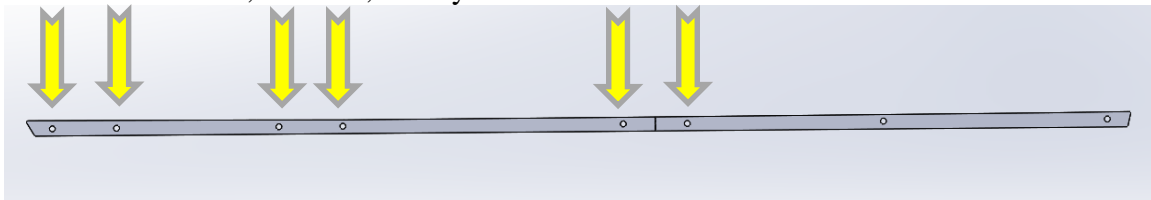

5. Do this for both sides.



2019-20XX JEEP GLADIATOR

600-56-0943



**Congratulations! Your Installation is now complete.
Thank You for your purchase!**