

2019-XX JEEP GLADIATOR

Headache Rack

INSTALLATION INSTRUCTIONS



SAFETY

Know safety, no injury. Know injury, no safety. ~Author Unknown

If there are any questions, call 1-855-HHTOUGH

- **READ ALL SAFETY INSTRUCTIONS BEFORE INSTALLATION**
 - FOLLOW ALL INSTRUCTIONS FOR PROPER ASSEMBLY
 - WEAR APPROPRIATE EYE PROTECTION
 - EXERCISE CARE WHEN LIFTING COMPONENTS
 - USE APPROPRIATE TORQUE FOR BOLTS



Suggested Torque Values For Steel Grade 5 Standard Bolts

BOLT DIAMETER (INCH)	THREADS PER INCH	TORQUE (POUND - FEET)
1/4	20	7
5/16	18	14
3/8	16	25
7/16	14	40
1/2	13	60
9/16	12	88
5/8	11	120
3/4	10	200
7/8	9	302
1	8	466

Suggested Torque Values For Steel Grade 8.8 Metric Bolts

BOLT DIAMETER (mm)	THREAD PITCH (mm)	TORQUE (POUND-FEET)
6	1.0	7
8	1.25	16
10	1.5	32
12	1.75	55
14	2.0	88
16	2.0	140
18	2.5	195
20	2.5	275
22	2.5	375
24	3.0	475

I. PARTS LIST

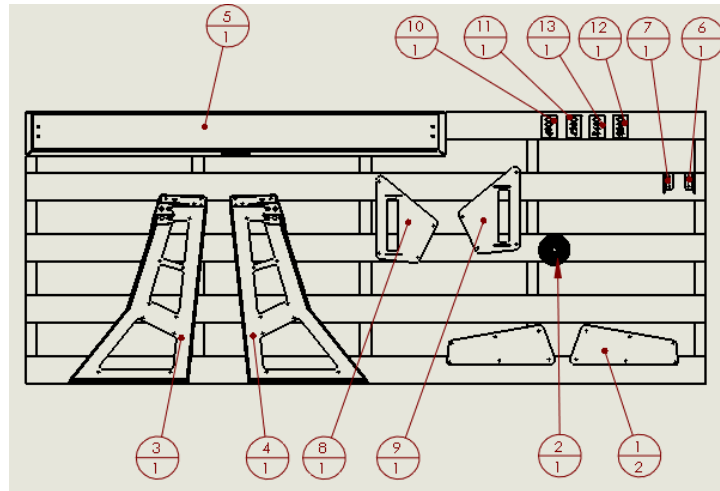

ITEM NO.	QTY.	PART NUMBER	DESCRIPTION
1	2	601-56-3235	SIDE PLATE 1
2	1	601-56-3744	3048MM LENGTH FOAM ROLL
3	1	601-56-4572	LEFT UPRIGHT WELDMENT
4	1	601-56-4573	RIGHT UPRIGHT WELDMENT
5	1	601-56-4811	TOP CAP WELDMENT - HH
6	1	601-56-4813	LEFT BAR BRACKET
7	1	601-56-4814	RIGHT BAR BRACKET
8	1	601-56-4863	LEFT SIDE PLATE 2 WELDMENT
9	1	601-56-4864	RIGHT SIDE PLATE 2 WELDMENT
10	1	60K-56-0069	HARDWARE KIT # 69
11	1	60K-56-0157	HARDWARE KIT # 157
12	1	60K-56-0158	HARDWARE KIT # 158
13	1	60K-56-0192	HARDWARE KIT # 192

REMOVE CONTENTS FROM BOX AND VERIFY ALL PARTS ARE PRESENT.

If there are any questions, call 1-855-HHTOUGH or email HHORDERS@hammerheadarmor.com

II. TOOL LIST

1. Basic tool set
2. 1/2" socket
3. 1/2" wrench
4. 13mm wrench
5. Torx T40 bit
6. Torx T30 bit
7. Large Phillips Head screwdriver
8. Rubber Hammer
9. Scissors
10. 3/8" drill bit

III. PREPARING FOR INSTALLATION

1. Using scissors, cut four 4.5" (115mm) length foam strips and apply two of them on the top of each upright. (See Pic)

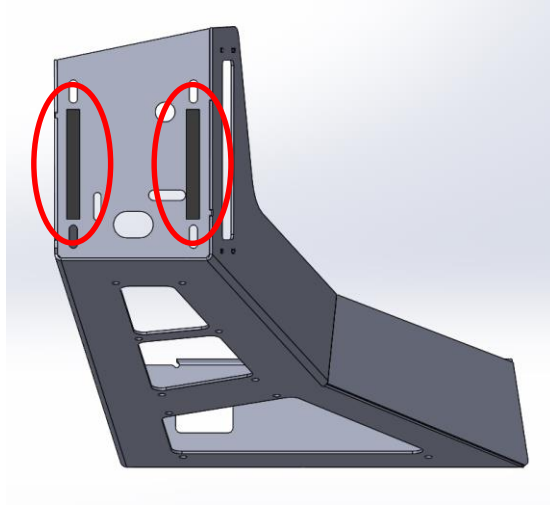

2. Using scissors, cut four 13.75" (350mm) length foam strips and apply two of them to the bottom of each upright (See Pic)

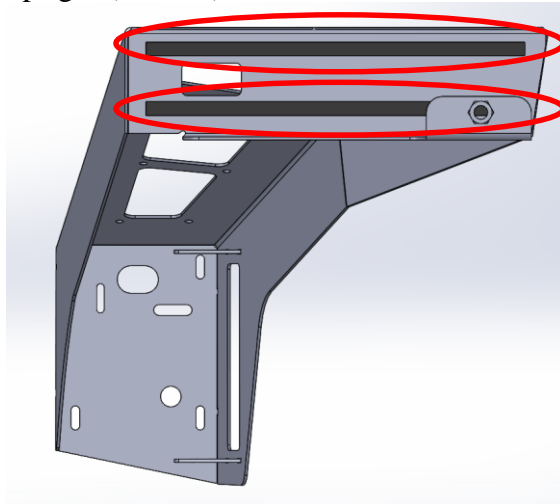

3. Locate each of the Side Plates 1 and 2, and hardware kit #157. Using a Torx T-30 and ½” socket, install the side plates into both left and right uprights using one torx head screw, one flat washer, and one nylock hex nut per hole. You will use ten per side. (See Pic)

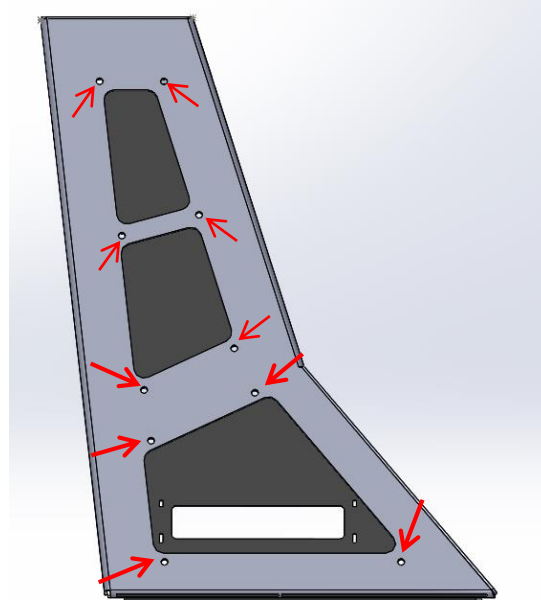

4. Locate the Left Bar Bracket and the Right Bar Bracket. Install the brackets on the ends of your 50” light bar. (See Pic)

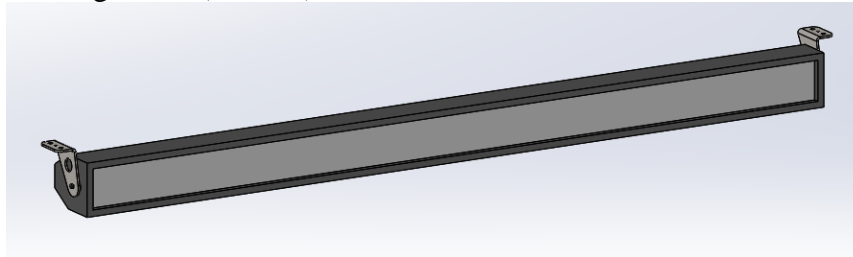

5. Once the brackets are installed on the light bar, install the light bar into the top cap weldment using hardware from hardware kit #158. Insert four carriage bolts through the top cap weldment and the brackets (see pic), and then secure it using the four provided flat washers and nylock hex nuts. Use a ½” socket to tighten the nuts.

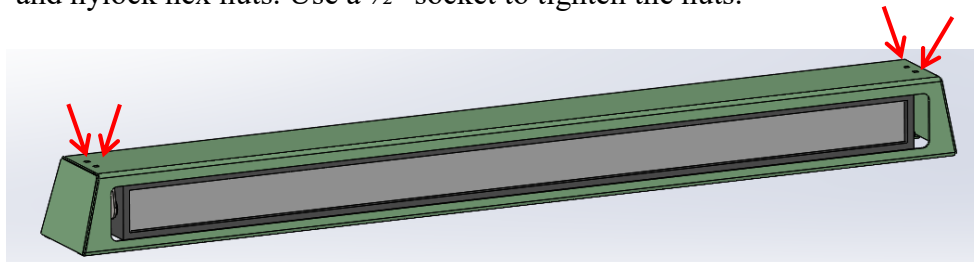

6. Place the top cap on top of the uprights. From hardware kit #69 use eight T30 torx screws and eight flat washers to secure the top cap to the uprights. Do not fully tighten.



7. You are now ready to install the Hammerhead Headache Rack on your truck!

IV. INSTALLATION OF HAMMERHEAD HEADACHE RACK

1. Place Headache rack on truck and align with bedrails. (Make sure to leave enough room between Headache rack and cab to remove your hardtop)
2. Mark the top of your bedrail for drilling in the center of the two slots on each side.
3. Remove the Headache rack and drill the marked locations with a 3/8" drill bit.
4. Place Headache rack back on truck and secure with hardware from kit #192. You will use a T40 bit and a 13mm wrench.
5. Center uprights on top cap and tighten all hardware.
6. Route and wire lights to your specification.



**Congratulations! Your product installation is now complete.
Thank you for your purchase.**