

# 2018-20XX JEEP JL 2 DOOR

## HAMMERHEAD BOTTOM TRIM INSTALLATION INSTRUCTIONS



## SAFETY

**Know safety, no injury. Know injury, no safety. ~Author Unknown**

If there are any questions, call 1-855-HHTOUGH

- **READ ALL SAFETY INSTRUCTIONS BEFORE INSTALLATION**
  - FOLLOW ALL INSTRUCTIONS FOR PROPER ASSEMBLY
  - WEAR APPROPRIATE EYE PROTECTION
  - EXERCISE CARE WHEN LIFTING COMPONENTS
  - USE APPROPRIATE TORQUE FOR BOLTS

### SUGGESTED TORQUE VALUES FOR STEEL GRADE SAE 5 BOLTS

BOLT DIAMETER (INCH)	TREADS PER INCH	TORQUE (POUND-FEET)
1/4	20	7
5/16	18	14
3/8	16	25
7/16	14	40
1/2	13	60
9/16	12	88
5/8	11	120
3/4	10	200
7/8	9	302
1	8	466



2018-20XX Jeep JL

## I. PARTS LIST

ITEM NO.	QTY	PART NUMBER	DESCRIPTION
1	2	601-56-4536	BOTTOM TRIM 2 DOOR
2	1	60k-56-0101	HARDWARE KIT #101

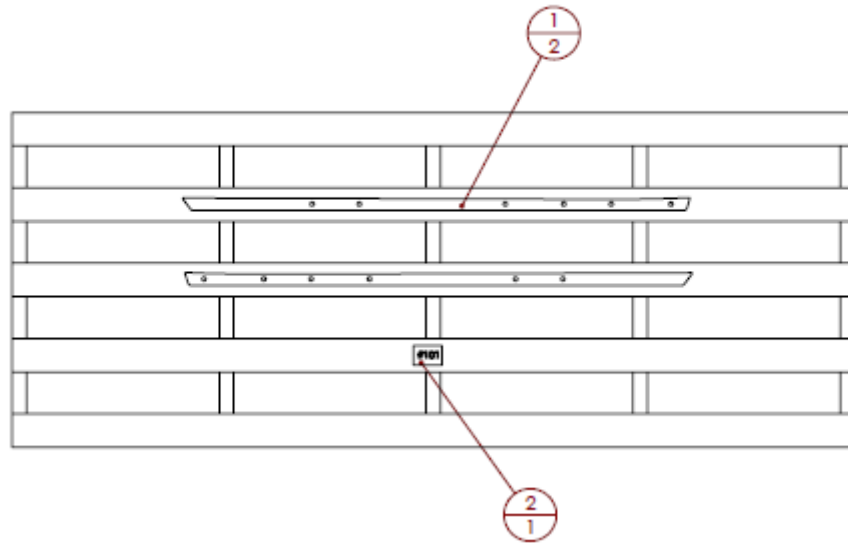

**REMOVE CONTENTS FROM BOX AND VERIFY ALL PARTS ARE PRESENT.**

**If there are any questions, call 1-855-HHTOUGH or email  
HHORDERS@hammerheadarmor.com**

## II. TOOL LIST

1. Basic tool set
2. Torx 40 socket
3. Torx 30 socket
4. 10mm socket
5. 13mm wrench

## III. INSTALLATION OF HAMMERHEAD 2 DOOR BOTTOM TRIM

1. Use the provided foam to line the back of the trim in order to protect the paint on your Jeep.

## 2018-20XX Jeep JL

2. On the bottom of the front fender along the OE bottom edge of the Jeep there are two 10mm bolts. Remove these bolts.



3. Place the trim piece on the Jeep. Using the Torx 30 socket install the two front replacement bolts. Use two 6mm bolts and two 6mm black washers as shown below.





## 2018-20XX Jeep JL

4. Using the Torx 40 socket and the 13mm wrench install four 8mm bolts, four 8mm washers and four 8mm nylock nuts as shown below.



5. Repeat the process on the other side



Congratulations! Your Hammerhead Bottom Trim installation is now complete.

Thank you for your purchase.