

2018 – 20XX JEEP JL REAR INNER FENDERS

ASSEMBLY AND INSTALLATION INSTRUCTIONS



SAFETY

Know Safety, no injury. Know injury, no safety. ~Author Unknown
If there are any questions, call 1-855-HHTOUGH

- **READ ALL SAFETY INSTRUCTIONS BEFORE INSTALLATION**
 - FOLLOW ALL INSTRUCTIONS FOR PROPER ASSEMBLY
 - WEAR APPROPRIATE EYE PROTECTION
 - EXERCISE CARE WHEN LIFTING COMPONENTS
 - USE APPROPRIATE TORQUE FOR BOLTS
 - BLUE THREAD LOCKING COMPOUND IS RECOMMENDED ON ALL BOLTS

SUGGESTED TORQUE VALUES FOR STEEL GRADE SAE 5 BOLTS

BOLT DIAMETER (INCH)	TREADS PER INCH	TORQUE (POUND-FEET)
1/4	20	7
5/16	18	14
3/8	16	25
7/16	14	40
1/2	13	60
9/16	12	88
5/8	11	120
3/4	10	200
7/8	9	302
1	8	466

I. PARTS LIST

ITEM NO.	QTY	PART NUMBER	DESCRIPTION
1	1	601-56-4526	LEFT REAR 1
2	1	601-56-4527	RIGHT REAR 1
3	1	601-56-4528	LEFT REAR 2
4	1	601-56-4529	RIGHT REAR 2
5	1	601-56-4530	LEFT REAR 3
6	1	601-56-4531	RIGHT REAR 3
7	1	60K-56-0180	HARDWARE KIT #180

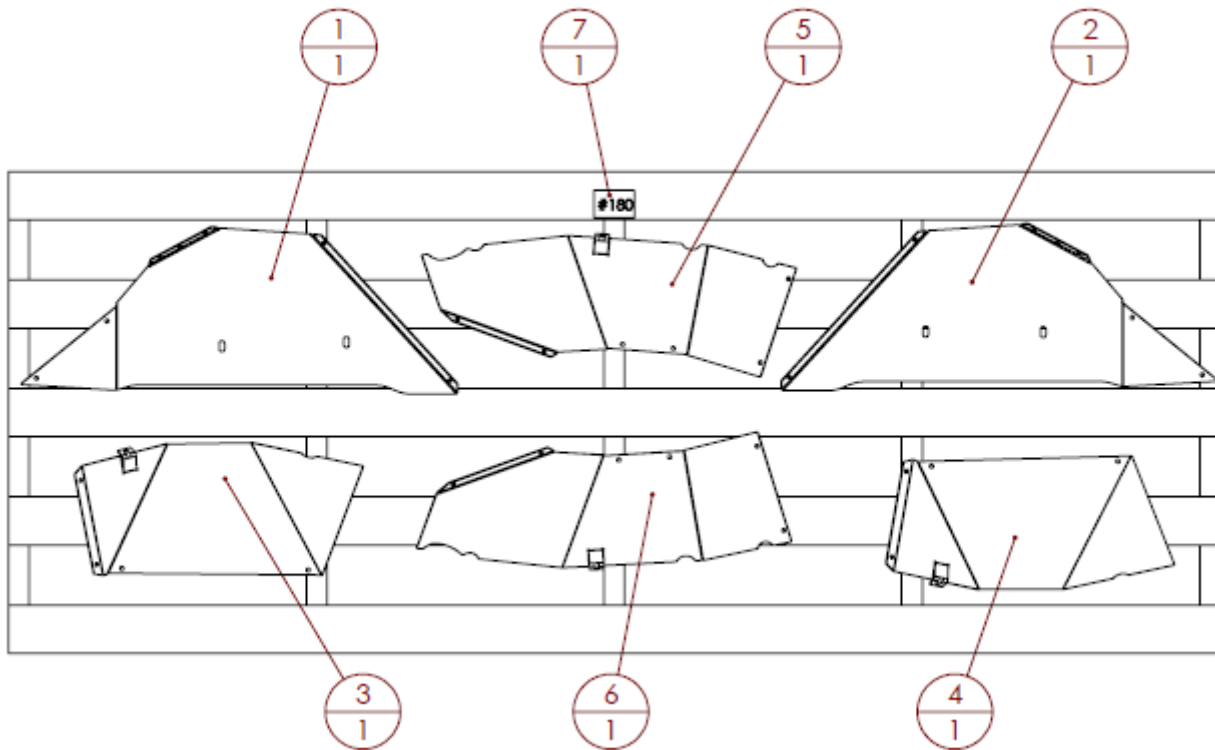

\

REMOVE CONTENTS FROM BOX AND VERIFY ALL PARTS ARE PRESENT.

If there are any questions, call 1-855 HHTOUGH or email HHORDERS@hammerheadarmor.com

II. TOOL LIST

1. A Good Friend
2. Basic Tool Kit
3. Torx 30
4. 10mm wrench

III. VEHICLE PREPARATION

1. Remove the OE inner fenders if they have not been removed already.

IV. REAR INNER FENDER ASSEMBLY

1. Using a torx 30 and a 10mm wrench, assemble left rear inner fender as shown below. Use two 6mm bolts and two 6mm nuts. Do not fully tighten.

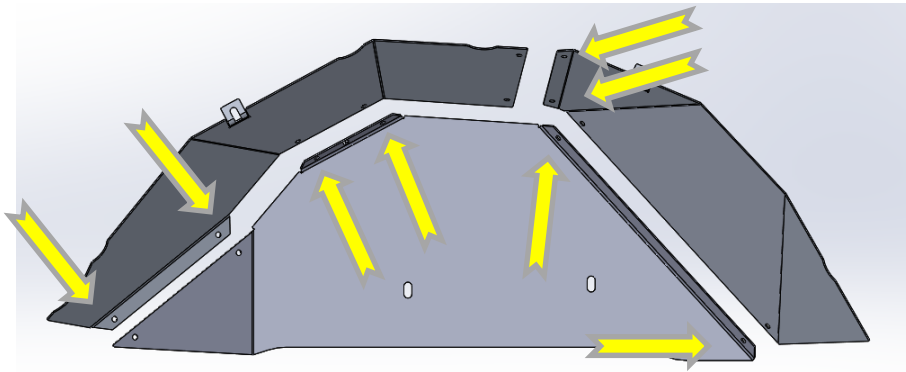

2. Attach two 6mm clip nuts to the locations shown below.

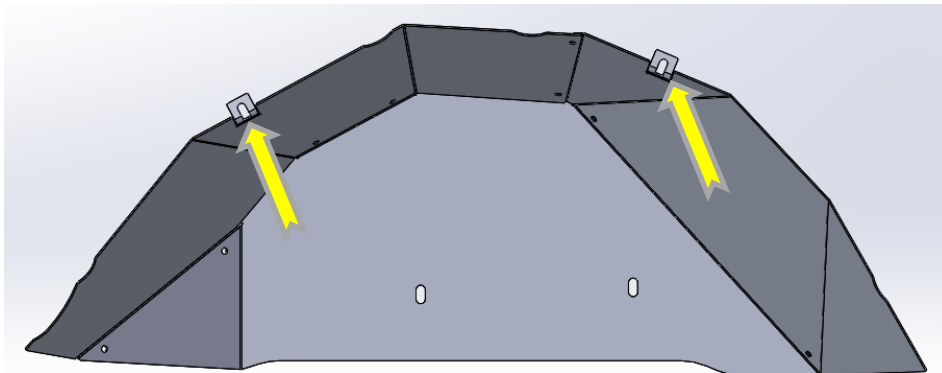

3. Do this for both sides.

V. REAR INNER FENDER INSTALL

1. Attach two 6mm clip nuts in the holes shown below.

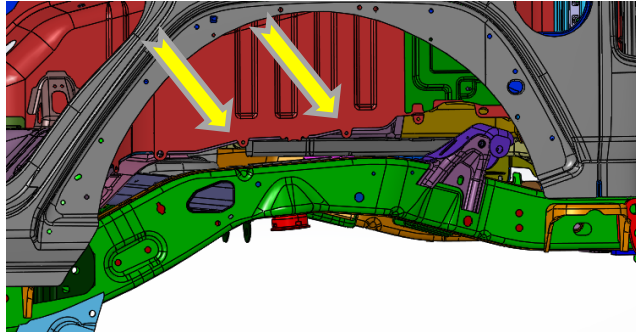

2. Place the Inner fender in the wheel well.
3. Using a torx 30, install two 6mm bolts in the location shown below.

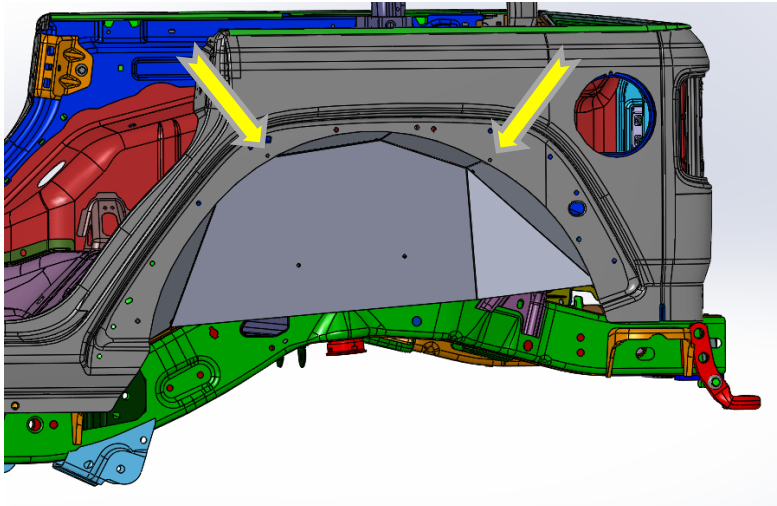

4. Using a torx 30, install two 6mm bolts in the locations shown below. Make sure to install the provided spacer behind the inner fender in these two locations.

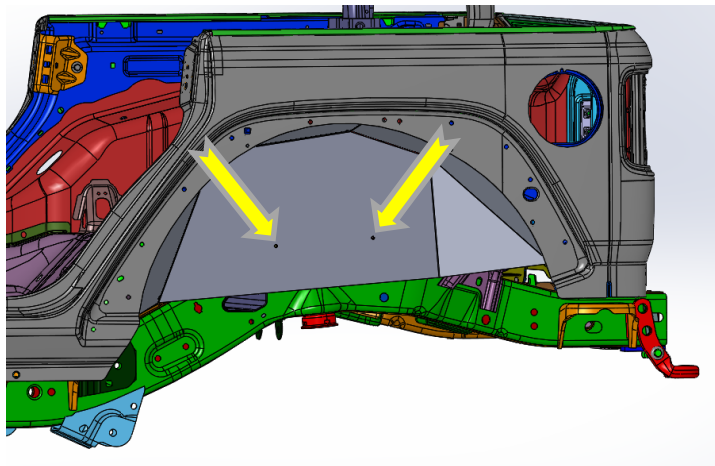

5. Do this for the other side.

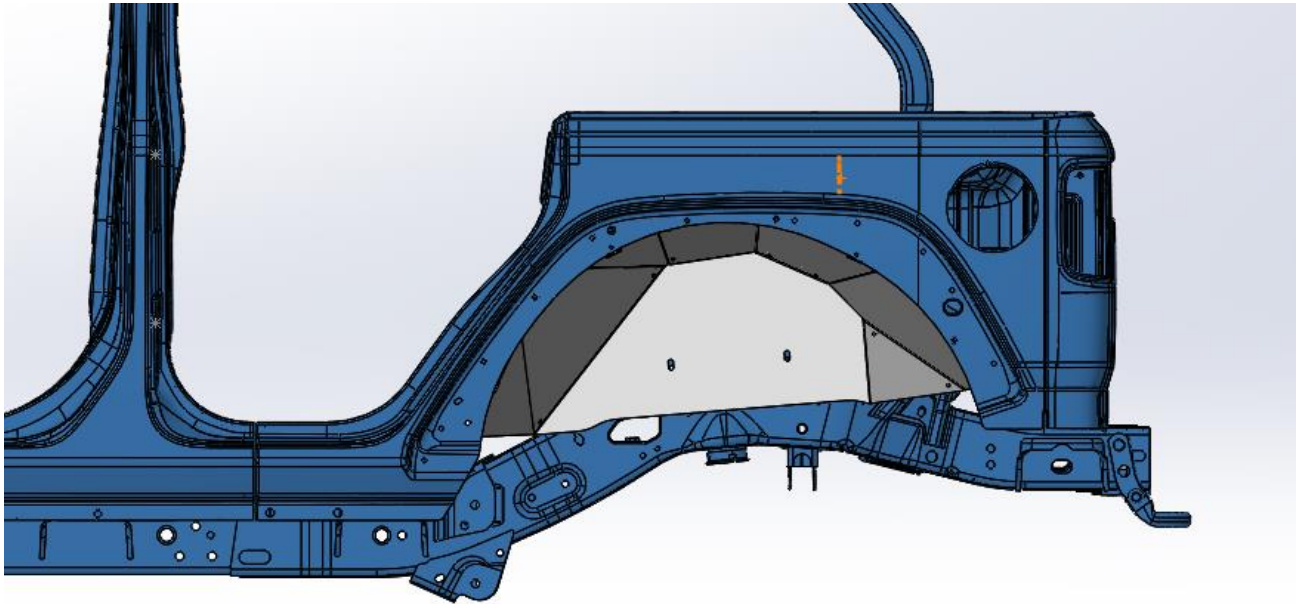

**Congratulations! Your Installation is now complete.
Thank You for your purchase!**