

2017-XX FORD F250-350

Headache Rack

INSTALLATION INSTRUCTIONS



SAFETY

Know safety, no injury. Know injury, no safety. ~Author Unknown

If there are any questions, call 1-855-HHTOUGH

- **READ ALL SAFETY INSTRUCTIONS BEFORE INSTALLATION**
 - FOLLOW ALL INSTRUCTIONS FOR PROPER ASSEMBLY
 - WEAR APPROPRIATE EYE PROTECTION
 - EXERCISE CARE WHEN LIFTING COMPONENTS
 - USE APPROPRIATE TORQUE FOR BOLTS

SUGGESTED TORQUE VALUES FOR STEEL GRADE SAE 5 BOLTS

BOLT DIAMETER (INCH)	TREADS PER INCH	TORQUE (POUND-FEET)
1/4	20	7
5/16	18	14
3/8	16	25
7/16	14	40
1/2	13	60
9/16	12	88
5/8	11	120
3/4	10	200
7/8	9	302
1	8	466

I. PARTS LIST

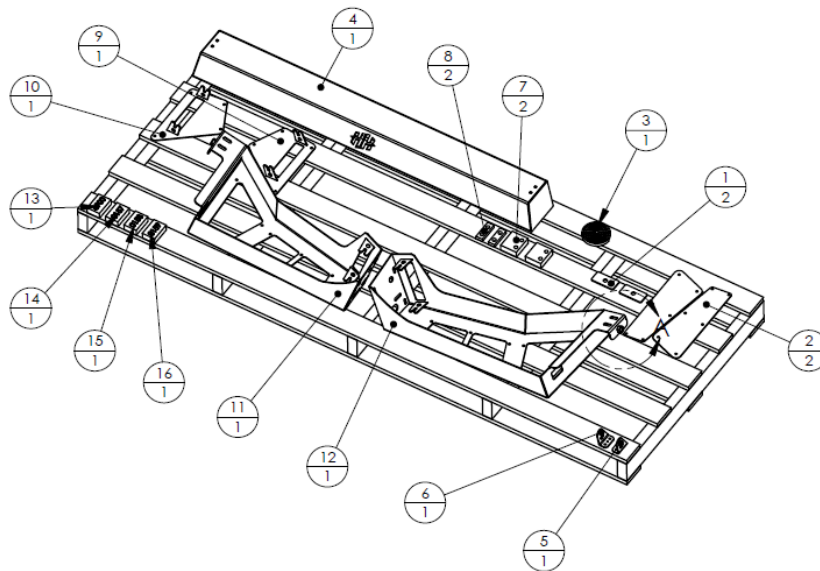

ITEM NO.	QTY	PART NUMBER	DESCRIPTION
1	2	601-56-1442	LIGHT BAR WASHER
2	2	601-56-3235	SIDE PLATE 1
3	1	601-56-3744	3048MM LENGTH FOAM ROLL
4	1	601-56-4811	TOP CAP WELDMENT - HH
5	1	601-56-4813	LEFT BAR BRACKET
6	1	601-56-4814	RIGHT BAR BRACKET
7	2	601-56-4820	LARGE CLAMP BLOCK
8	2	601-56-4821	NYLON CLAMP SPACER
9	1	601-56-4863	LEFT SIDE PLATE 2 WELDMENT
10	1	601-56-4864	RIGHT SIDE PLATE 2 WELDMENT
11	1	601-56-4892	LEFT UPRIGHT WELDMENT
12	1	601-56-4893	RIGHT UPRIGHT WELDMENT
13	1	60K-56-0069	HARDWARE KIT #69
14	1	60K-56-0157	HARDWARE KIT #157
15	1	60K-56-0158	HARDWARE KIT #158
16	1	60K-56-0159	HARDWARE KIT #159

REMOVE CONTENTS FROM BOX AND VERIFY ALL PARTS ARE PRESENT.

If there are any questions, call 1-855-HHTOUGH or email HHORDERS@hammerheadarmor.com

II. TOOL LIST

1. Basic tool set
2. 1/2" socket
3. 1/2" wrench
4. Torx T40 bit
5. Torx T30 bit
6. Large Phillips Head screwdriver
7. Rubber Hammer
8. Scissors

III. PREPARING FOR INSTALLATION

1. Locate the two large clamp blocks. Using the four nutserts from hardware kit #159, insert one nutsert into each hole in the large clamp blocks. You will need to use a rubber hammer to bump the nutsert down until it is fully seated. (See Pic)



2. Using scissors, cut four 4.5" (115mm) length foam strips and apply two of them on the top of each upright. (See Pic)

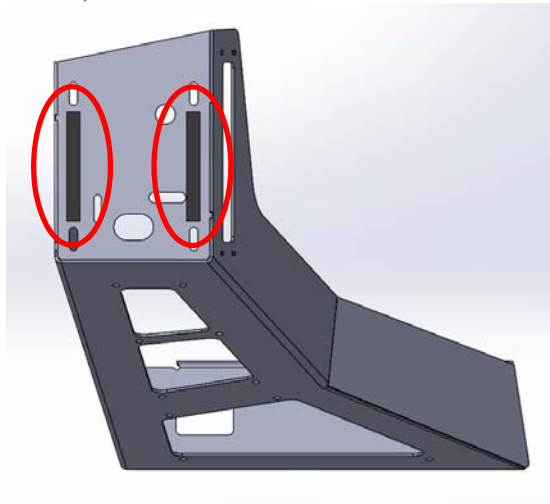

3. Using scissors, cut four 13.75" (350mm) length foam strips and apply two of them to the bottom of each upright. (See Pic)

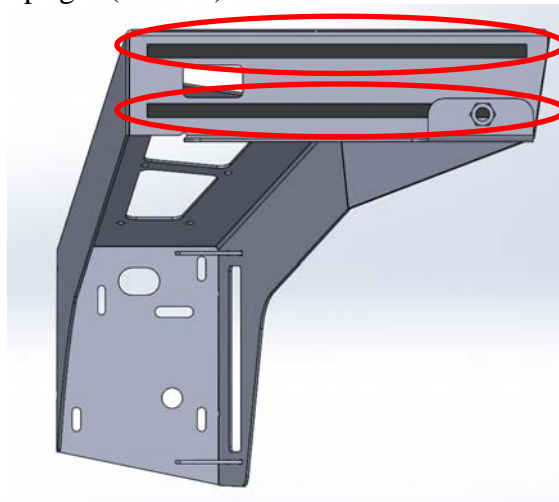

4. Locate each of the Side Plates 1 and 2, and hardware kit #157. Using a Torx T-30 and ½” socket, install the side plates into both left and right uprights using one torx head screw, one flat washer, and one nylock hex nut per hole. You will use ten per side. (See Pic)

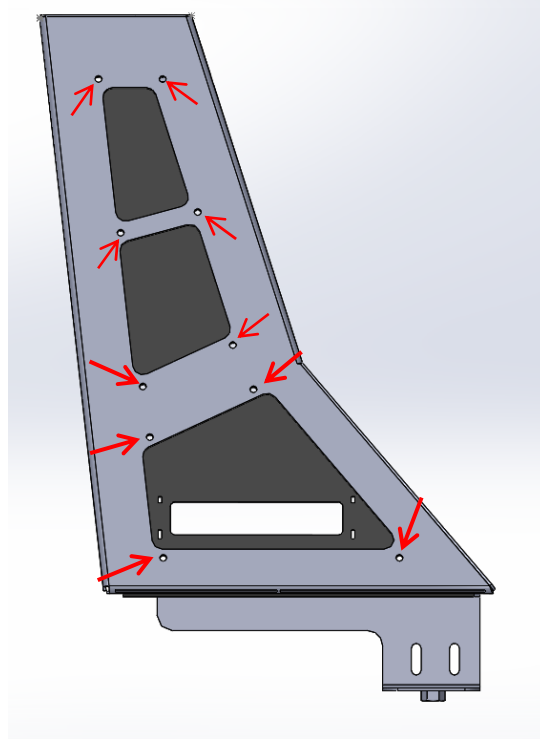

5. Locate the Left Bar Bracket and the Right Bar Bracket. Install the brackets on the ends of your 50” light bar. (See Pic)

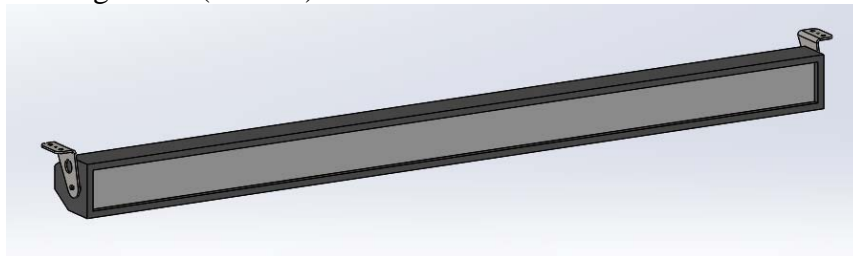

6. Once the brackets are installed on the light bar, install the light bar into the top cap weldment using hardware from hardware kit #158. Insert four carriage bolts through the top cap weldment and the brackets (see pic), and then secure it using the four provided flat washers and nylock hex nuts. Use a ½” socket to tighten the nuts.

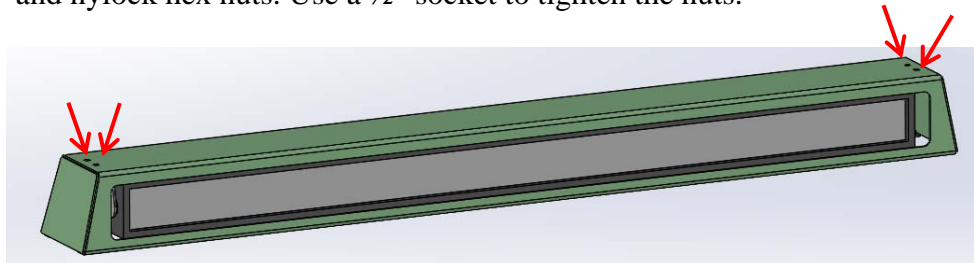

7. You are now ready to install the Hammerhead Headache Rack on your truck!

IV. INSTALLATION OF HAMMERHEAD HEADACHE RACK

1. Remove the stake-pocket caps from the bed rails. (See picture below)



2. Place the left upright on the bed rail cap. Align the rectangular cutout in the bottom of the upright with the rectangular opening in the top of the bed rail. Use a clamp to secure it temporarily. Repeat this step with the right upright.



3. Using hardware from hardware kit #159, the nylon clamp block, and the nylon clamp spacer, secure the uprights to the side of the bed rail. Insert two Torx 40 bolts and two flat washers through the two slots on the side of the upright. Insert one 1/2" hex bolt and one flat washer into the nut on the bottom of the upright. (See Pic) Do this for both sides. Use a Torx 40 bit and a 3/4" socket or wrench to tighten the bolts

Place one flat washer on one Torx 40 bolt and insert through slot, nylon spacer, and into nylon clamp block.

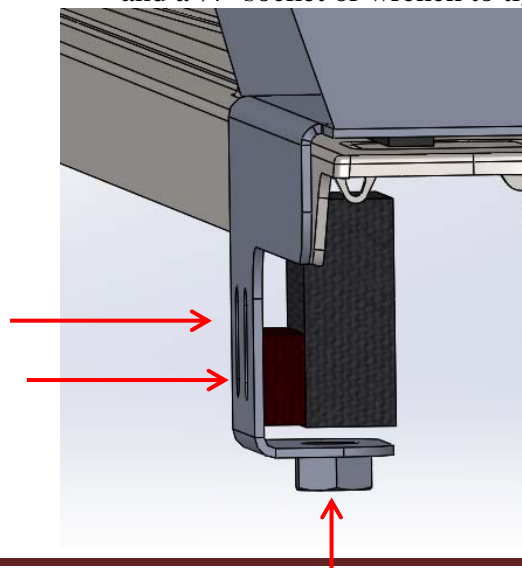

4. Insert the large rectangular washer (601-56-1442) onto the toggle bolt, then insert the toggle bolt into each stake pocket and tighten the toggle bolt using a Phillips head screwdriver.

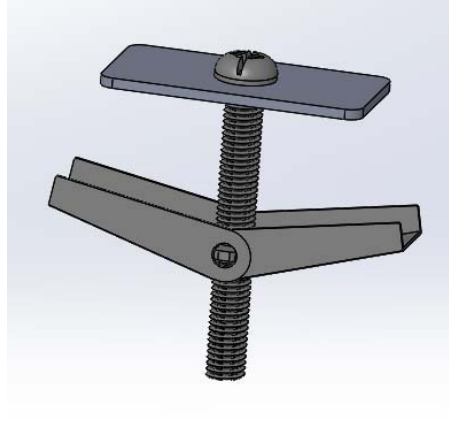

5. Place the top cap on top of the uprights. From hardware kit #69 use eight T30 torx screws and eight flat washers to secure the top cap to the uprights. Do not fully tighten.

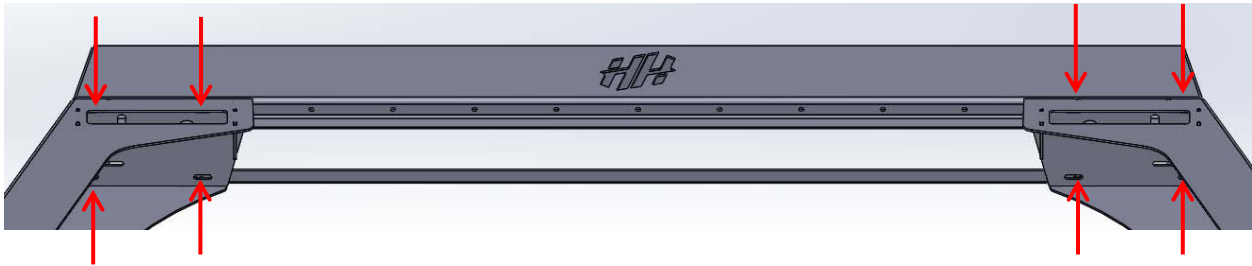

6. Center uprights on top cap and tighten all hardware.
7. Route and wire lights to your specification.



**Congratulations! Your product installation is now complete.
Thank you for your purchase.**