

2018-20XX JEEP JL 4 DOOR

HAMMERHEAD BOTTOM TRIM INSTALLATION INSTRUCTIONS



SAFETY

Know safety, no injury. Know injury, no safety. ~Author Unknown

If there are any questions, call 1-855-HHTOUGH

- **READ ALL SAFETY INSTRUCTIONS BEFORE INSTALLATION**
 - FOLLOW ALL INSTRUCTIONS FOR PROPER ASSEMBLY
 - WEAR APPROPRIATE EYE PROTECTION
 - EXERCISE CARE WHEN LIFTING COMPONENTS
 - USE APPROPRIATE TORQUE FOR BOLTS

California Proposition 65



WARNING

Cancer and Reproductive Harm

www.P65Warnings.ca.gov

DO NOT PAINT OVER THIS LABEL. REPLACE IF DAMAGED OR LOST

DKB150_00

Suggested Torque Values For Steel Grade 5 Standard Bolts		
BOLT DIAMETER (INCH)	THREADS PER INCH	TORQUE (POUND - FEET)
1/4	20	7
5/16	18	14
3/8	16	25
7/16	14	40
1/2	13	60
9/16	12	88
5/8	11	120
3/4	10	200
7/8	9	302
1	8	466

Suggested Torque Values For Steel Grade 8.8 Metric Bolts		
BOLT DIAMETER (mm)	THREAD PITCH (mm)	TORQUE (POUND-FEET)
6	1.0	7
8	1.25	16
10	1.5	32
12	1.75	55
14	2.0	88
16	2.0	140
18	2.5	195
20	2.5	275
22	2.5	375
24	3.0	475

I. PARTS LIST

ITEM NO.	QTY	PART NUMBER	DESCRIPTION
1	2	601-56-4829	TRIMPIECE 2
2	2	601-56-4830	TRIMPIECE 1
3	1	60k-56-0101	HARDWARE KIT #101

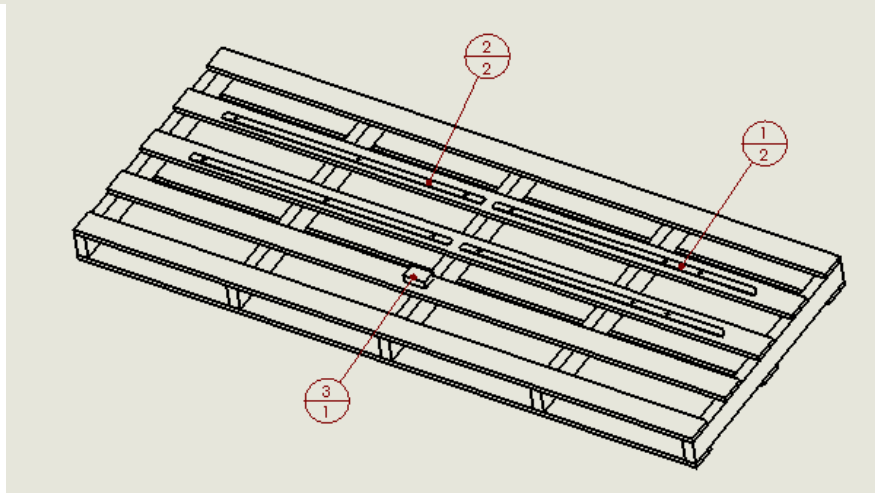



2018-20XX Jeep JL

**REMOVE CONTENTS FROM BOX AND VERIFY ALL PARTS ARE PRESENT.
If there are any questions, call 1-855-HHTOUGH or email
HHORDERS@hammerheadarmor.com**

II. TOOL LIST

1. Basic tool set
2. Torx 40 socket
3. Torx 30 socket
4. 10mm socket
5. 13mm wrench

III. INSTALATION OF HAMMERHEAD BOTTOM TRIM

1. Use the provided foam to line the back of the trim in order to protect the paint on your jeep.
2. On the bottom of the front fender along the OE bottom edge of the jeep there are 2 10mm bolts. Remove these bolts.
3. Place the trim pieces on the jeep as shown. The piece with spaced out holes goes towards the front and the piece with closer holes goes towards the back. The 2 pieces will meet in the middle.
4. Using the Torx 40 socket and the 13mm wrench install the rear piece. There will be 3 holes in the bottom lip of the jeep as indicated by the arrows below. Use three 8mm bolts, three 8mm washers and three 8mm nylock nuts.





2018-20XX Jeep JL

5. **Using the Torx 40 socket and the 13mm wrench install the rear bolt on the front piece. Use one 8mm bolt, one 8mm washer, and one 8mm nylock nut. Then using the Torx 30 socket install the 2 front replacement bolts. Use two 6mm bolts and two 6mm black washers.**

6. **Repeat the process on the other side**



Congratulations! Your Hammerhead Bottom Trim installation is now complete.

Thank you for your purchase.