

INSTALL INSTRUCTIONS



ROCK DEFENSE™ YJ/TJ REAR BUMPER

303144-2-KIT

KIT CONTENTS



- 4X 1/2"-13 NUT
- 16X 1/2"-13X 1-1/2" GRADE 8 BOLT
- 12X 1/2" BLACK WASHER
- 4X 1/2" LOCK WASHER

Note: We recommend test fitting prior to painting or powder coating the bumper.



RECOMMENDED TOOLS

Rubber Mallet
Tape Measure
Socket Set
Wrench Set
Drill
Drill Bit Set
C-Clamp

CAUTION

1. Read all instructions completely and carefully before you begin. If anything is not clear, please call our tech support line at 1.877.4X4.TOYS or 559.252.4950 before proceeding.
2. Check to make sure the kit is complete and that no parts are missing (refer to the Kit Contents Section on the first page of these instructions). If anything is missing, please contact Trail-Gear at 1.877.4X4.TOYS or 559.252.4950.
3. Park vehicle on a clean, dry, flat, level surface and block the tires so the vehicle cannot roll in either direction.
4. This kit is for off-road use only. It is recommended that the installation steps below be performed by a competent mechanic. Buyers and users of this product hereby expressly assume all risks associated with the installation and use of this kit.



INSTALL INSTRUCTIONS (CONT'D.)



STEP 1

(TJ only) Unbolt and remove plastic bumper end cap



STEP 2

Unbolt and remove OEM bumper. TJ models will have 4 bolts securing them to the frame.



STEP 2 CONTINUED

YJ Models will have 8 bolts securing OEM bumper to frame



STEP 3

Install bumper mount brackets using two holes on the outside of the frame using the supplied bolt, two washers, and nut. Tighten the bolts until they are snug.

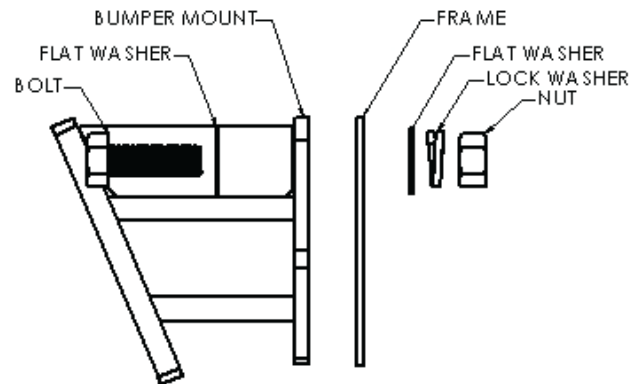

STEP 4

Ensure the bumper mount bracket is level with the top of the vehicle.



STEP 5

Measure from the outside of the threaded mounting plate to the outside of the opposite threaded mounting plate. The dimension should be 43- 3/8", there should also be an equal distance from the end of the mount to the end of the frame on both sides of the vehicle. If not use a rubber mallet to adjust the bumper mounting brackets.

INSTALL INSTRUCTIONS (CONT'D.)



STEP 5 CONTINUED



STEP 7

(If you have a YJ skip to step 8) Mark the center of the inside bolt holes. Center punch and drill to $\frac{1}{2}$ ", it is recommended to use a smaller pilot drill to prevent the drill bit from walking.



STEP 9

Install and tighten supplied bolts and washers. Repeat steps 8 and 9 on the opposite side of the vehicle.



STEP 6

Once the bumper mount brackets are in the correct position, ensure that the outer mounting bolts, installed in step 3, are tight



STEP 8

Slide supplied nut plate behind frame.



STEP 10

Slide bumper over mounts.



INSTALL INSTRUCTIONS (CONT'D.)



STEP 11

Install D-ring mounts using supplied hardware. The bolts will also pass through the bumper and thread into the bumper mounting brackets. We recommend getting all of the bolts started before tightening any of them. You may want to add thread locking compound to these bolts.



STEP 12

Tighten hardware.



Note: Due to the recessed receiver hitch we recommend using the hitch pin style shown with cotter pin groove instead of cotter pin hole.

REPLACEMENT PARTS

